



# **Neuroanatomy**

**Dr. Maha ELBeltagy**

**Associate Professor of Anatomy**

**Faculty of Medicine**

**The University of Jordan**

**2025**

# Learning objectives

- Enumerate the two types of brain fibers
- Differentiate types of white matter within the brain
- Enumerate and identify different types of association fibers within the brain
- Enumerate and identify different commissures within the brain
- Locate and differentiate projections from and to the cortex
- Distinguish detailed anatomical parts of the internal capsule, types of fibers inside each part and its blood supply and effect of lesion.
- Locate and identify different parts of basal nuclei, their functions and their anatomical relation to the internal capsule.
- know the effect of lesion of different parts of basal nuclei and their clinical significance and manifestation.



# Types of brain fibers

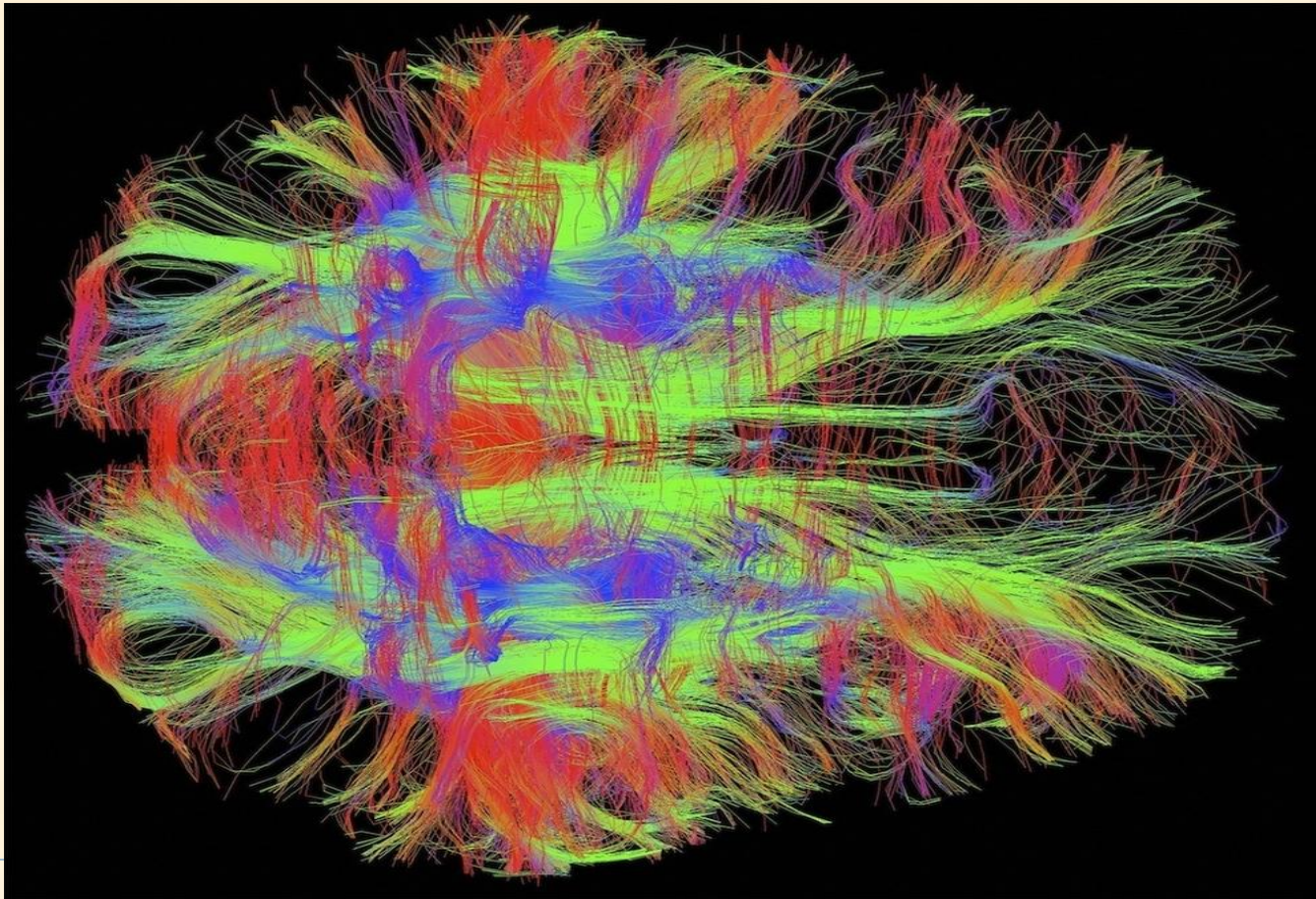

# THE WHITE MATTER OF THE BRAIN

The white matter of the brain consists of:

- 1) Association fibers:  
Connect different areas in the same hemisphere.
- 2) Commissural fibers:  
Connect similar areas in the 2 hemispheres.
- 3) Projection fibers: Fibers from & to the cerebral cortex.

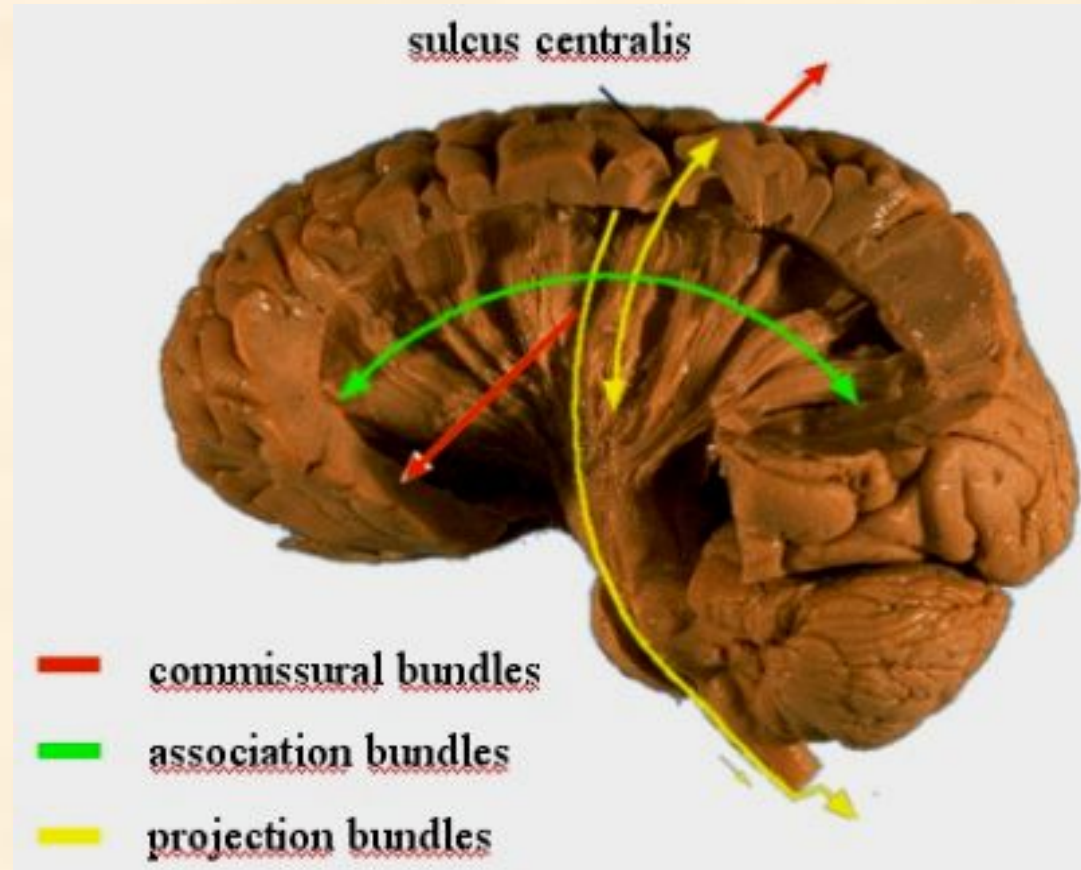

# Association fibers

There are short & long association fibers.

- A) **Short association fibers:** Connect adjacent gyri, forming U-shaped arcuate fibers in all parts of the hemisphere.
- B) **Long association fibers:**
- 1) **Superior longitudinal bundle:** Connects frontal, occipital & temporal regions.
  - 2) **Inferior longitudinal bundle:** Runs from temporal to occipital poles.
  - 3) **Cingulum:** Forms incomplete circle around corpus callosum. It begins near rostrum of corpus callosum & ends in the uncus connects it with hippocampus and cingulate gyrus.
  - 4) **Uncinate Fasciculus:** Runs from frontal to temporal poles.

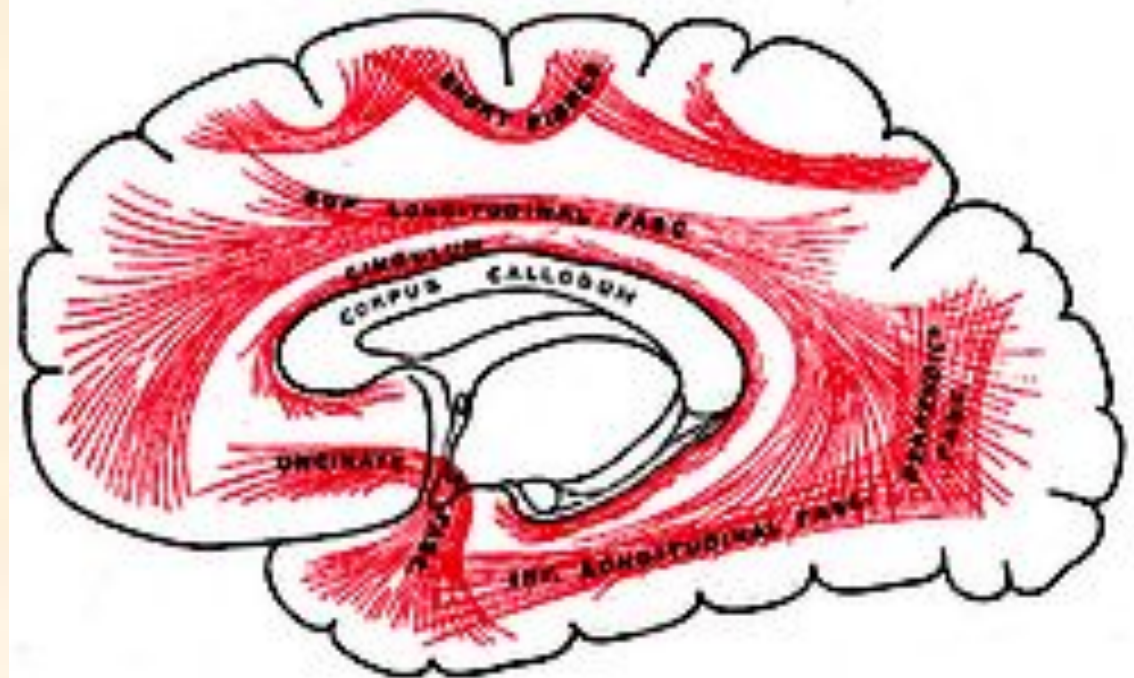

# Commissural fibers

- 1) **Anterior commissure**  
crosses the middle line within lamina terminalis (connect both piriform fossae) temporal lobes. acute pain and smell.
- 2) **Posterior commissure lower pineal stalk**  
(pupillary light reflex)(connect superior colliculi and pretectal nuclei)
- 3) **Habenular commissure: superior to pineal stalk connects right and left habenular nuclei** (connected to Amygdaloid nucleus) center of integration of olfactory, visceral pathways.
- 4) **Fornix commissure** (efferent of hippocampus) connects crura and body of the fornix across both hippocampi.
- 5) **Corpus Callosum.**

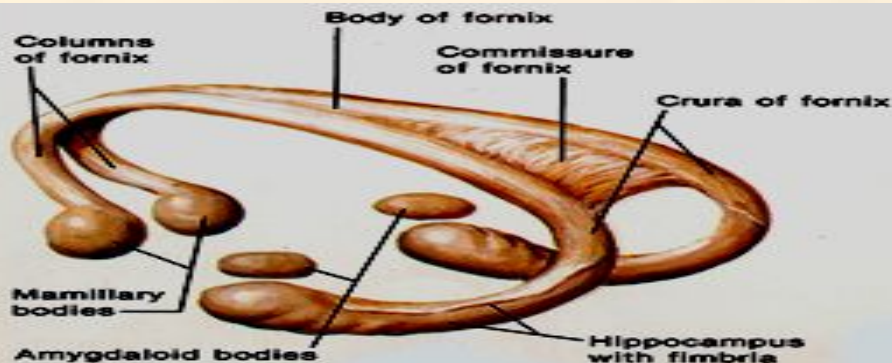
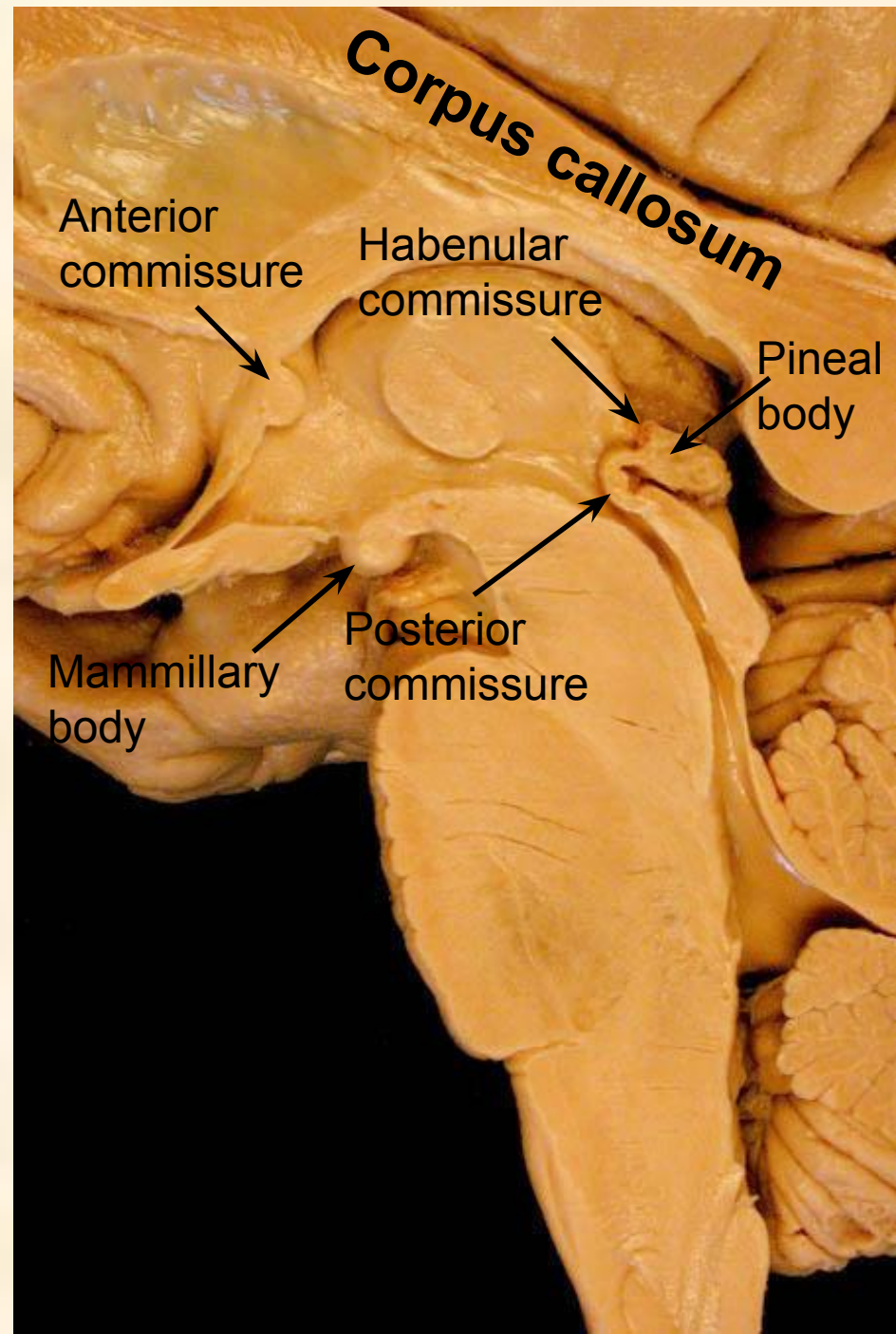

# 5- Corpus Callosum:

It is the great (10 cm) transverse commissure that connects the cerebral hemispheres & roofs the lateral ventricle (**except ant part of temporal lobes which are connected by the anterior commissure**).

It is divided into 4 parts ; rostrum, genu, body & splenium.

Fibers of the genu curve forwards to connect frontal lobes forming **“Forceps minor”**.

Fibers of splenium curve backwards to connect occipital lobes forming **“Forceps Major”**.

**Tapetum:** fibres of body and splenium intersecting with corona radiata of the internal capsule.

**Blood Supply:** It is supplied by anterior cerebral artery **except the splenium** by the posterior cerebral artery

**Lesion :** 1- callosal Syndrome (split brain)  
2- Apraxia

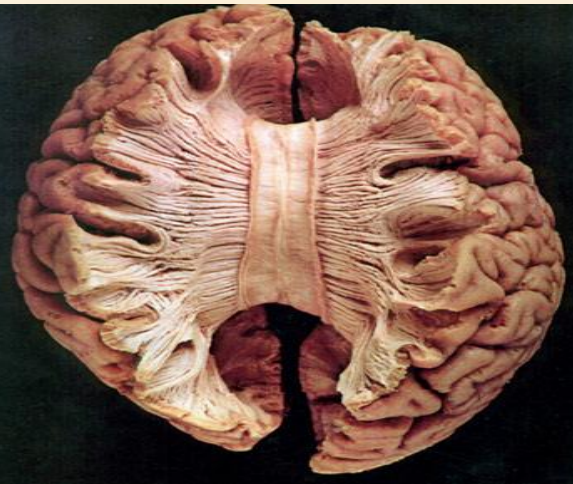
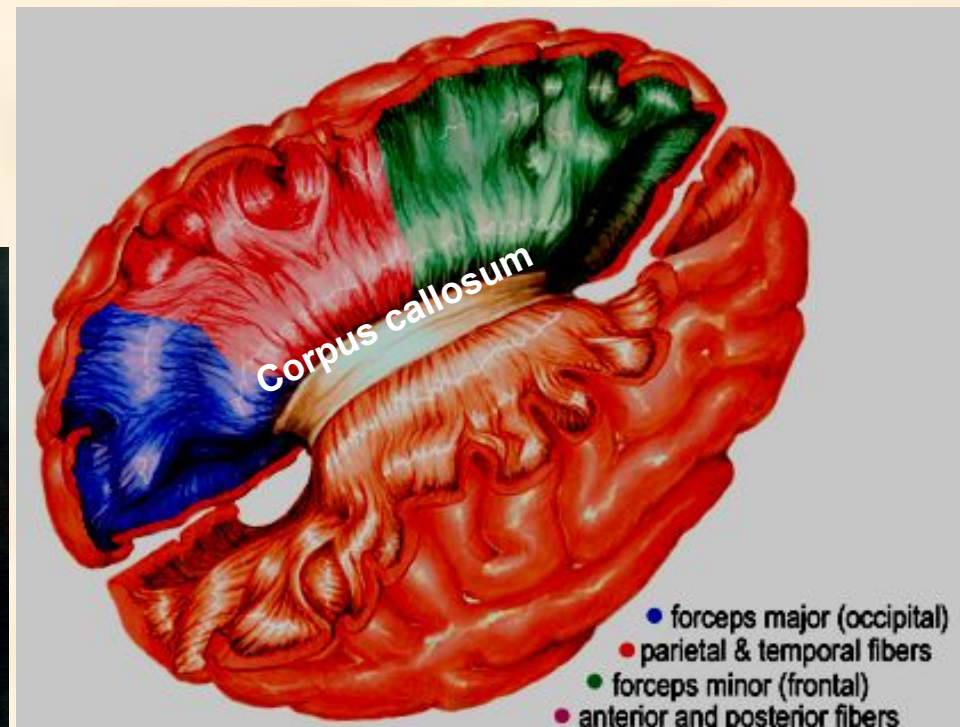
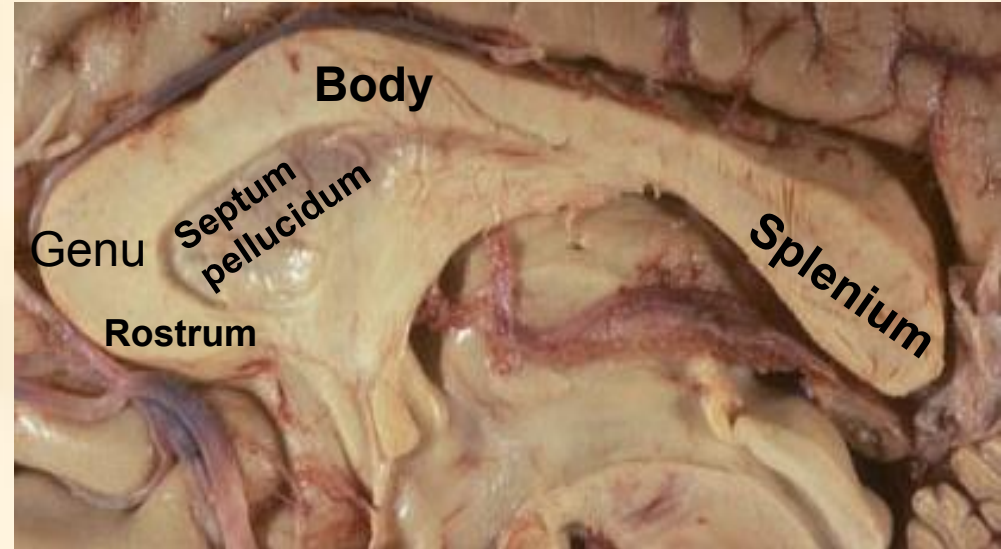

# Projection fibers

## A) Projection fibers TO the cortex:

Include all thalamo-cortical fibers (thalamic radiation).

- **Sensory radiation:** From PLVNT to area 3,1,2 in the postcentral gyrus.
- **Anterior thamic radiation :** from anterior thalamus to cingulate
- **Visual radiation:** from lateral geniculate body to the visual area 17 in the occipital lobe.
- **Auditory radiation:** from the medial geniculate body to the auditory area in the temporal lobe.

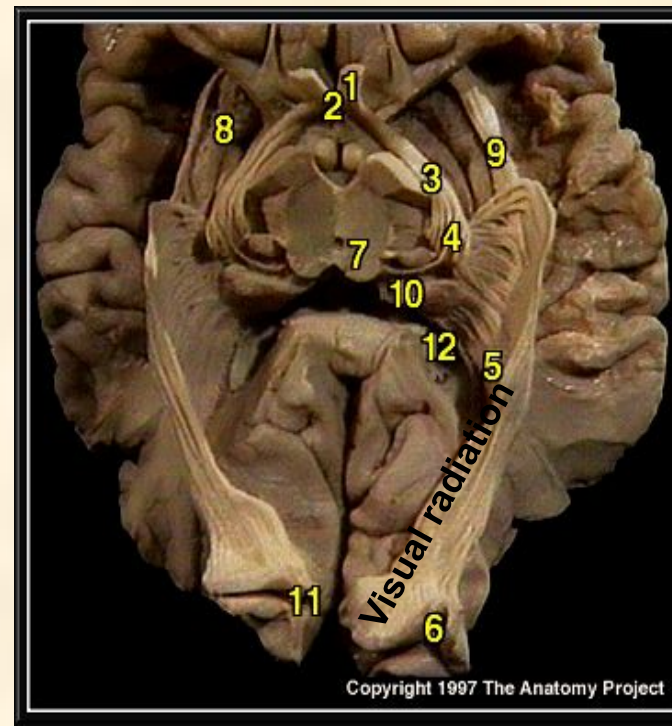
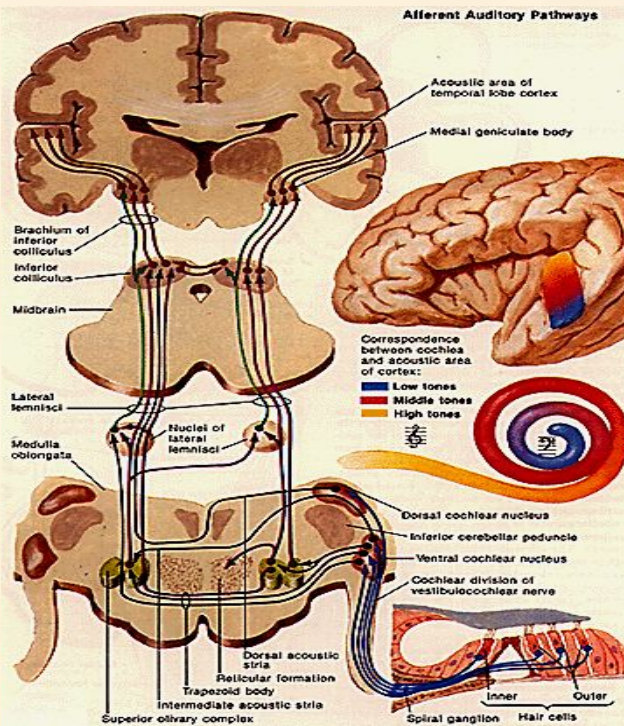
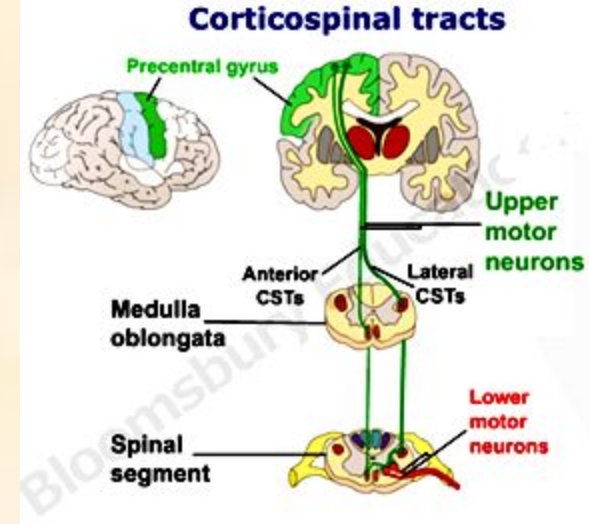

## **B) Projection fibers FROM the cortex:**

Include the following fibers:

- **Pyramidal tract.**
- **Extrapyramidal tracts.**
- **Cortico-pontine fibers.**
- **Cortico-thalamic fibers.**

Corona radiata

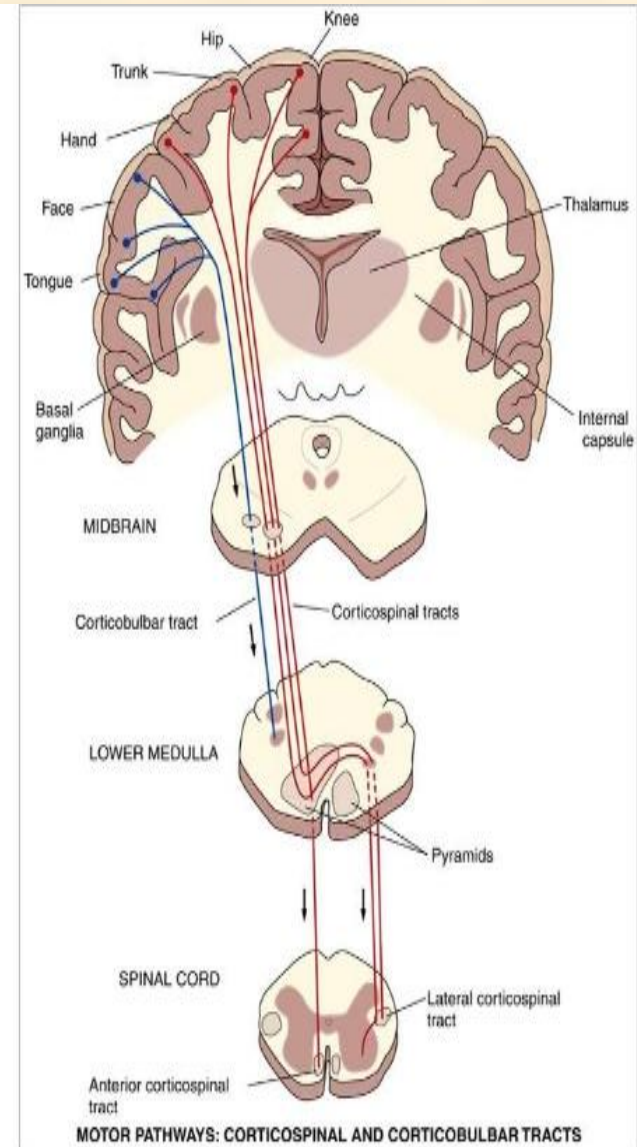

# Internal Capsule

It is a V-shaped bundle of projection fibers between thalamus, caudate & lentiform nuclei.

Lies on medial surface of lentiform nucleus separating it from caudate above and thalamus below.

Continuous above as **corona radiata** and below with **crus cerebri** of midbrain.

It is divided into **anterior limb**, **genu**, **posterior limb**, **retrolentiform** & **sublentiform** parts.

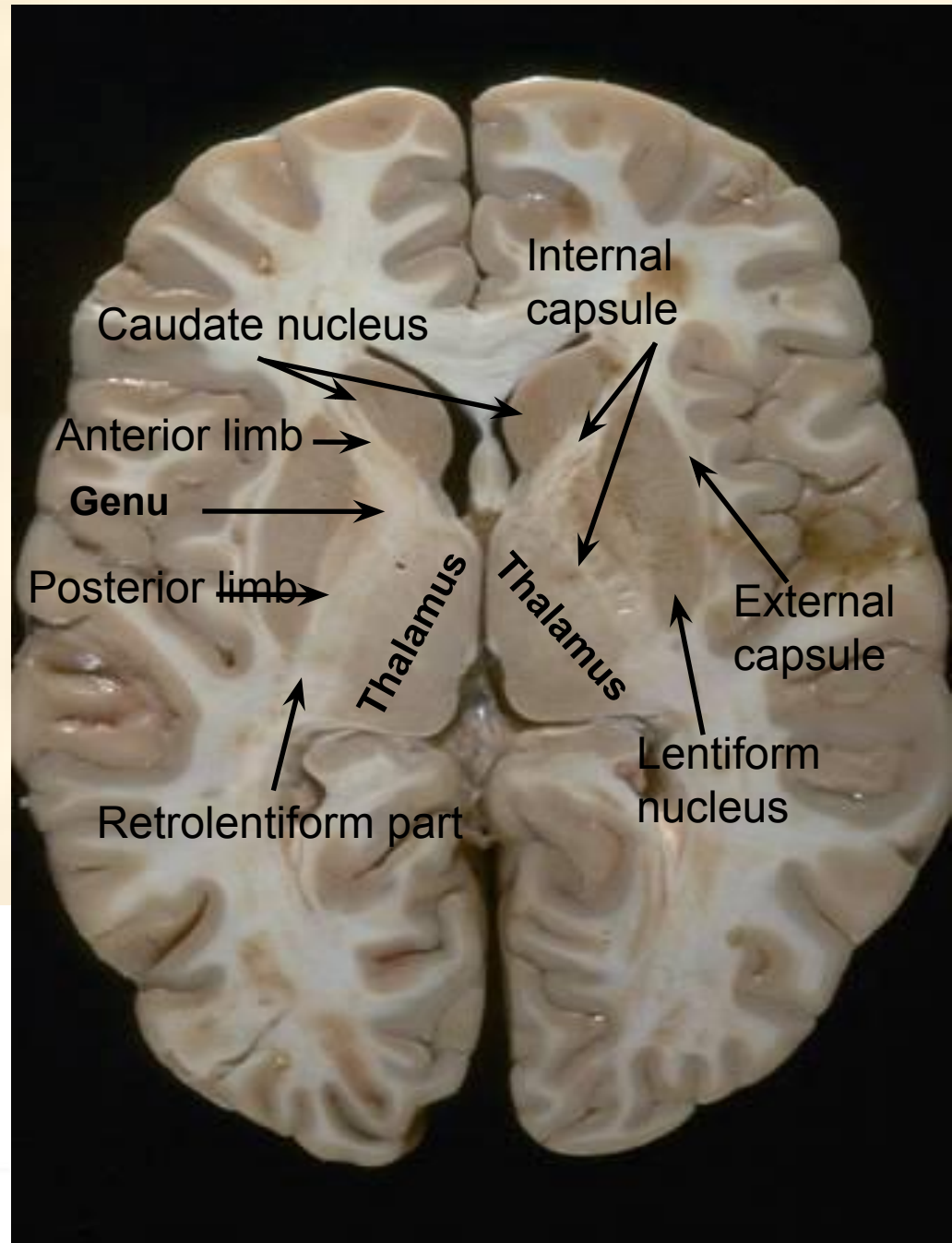
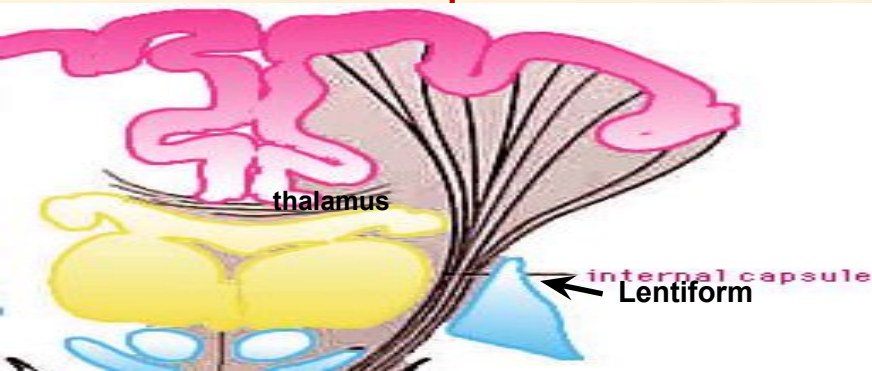

# Types of fibers in the internal capsule

- The **anterior limb** of the internal capsule contains:
  - 1) **Descending Frontopontine (fronto-ponto-cerebellar)** fibers project from frontal cortex to pons
  - 2) **Ascending Thalamocortical (Anterior thalamic radiation)** fibers connect the thalamus to the frontal lobes and cingulate gyrus
- The **genu** contains **corticobulbar** fibers which run between the cortex and the cranial nuclei in the brainstem.
- The **posterior limb** of the internal capsule contains:
  - **Descending anterior half Corticospinal fibers**: From motor area 4 to AHC's in the spinal cord.
  - **Ascending posterior half Sensory fibers (superior thalamic radiation)** from VP of thalamus to post central gyrus.
- **The retrolenticular part** contains fibers the **optic radiation (posterior thalamic radiation)**.
- **The sublenticular part** contains the **auditory radiation (Inferior thalamic radiation)**.
- **Lesion** :arterial /cerebral hemorrhage in high blood pressure patient (contralateral side)

(B)

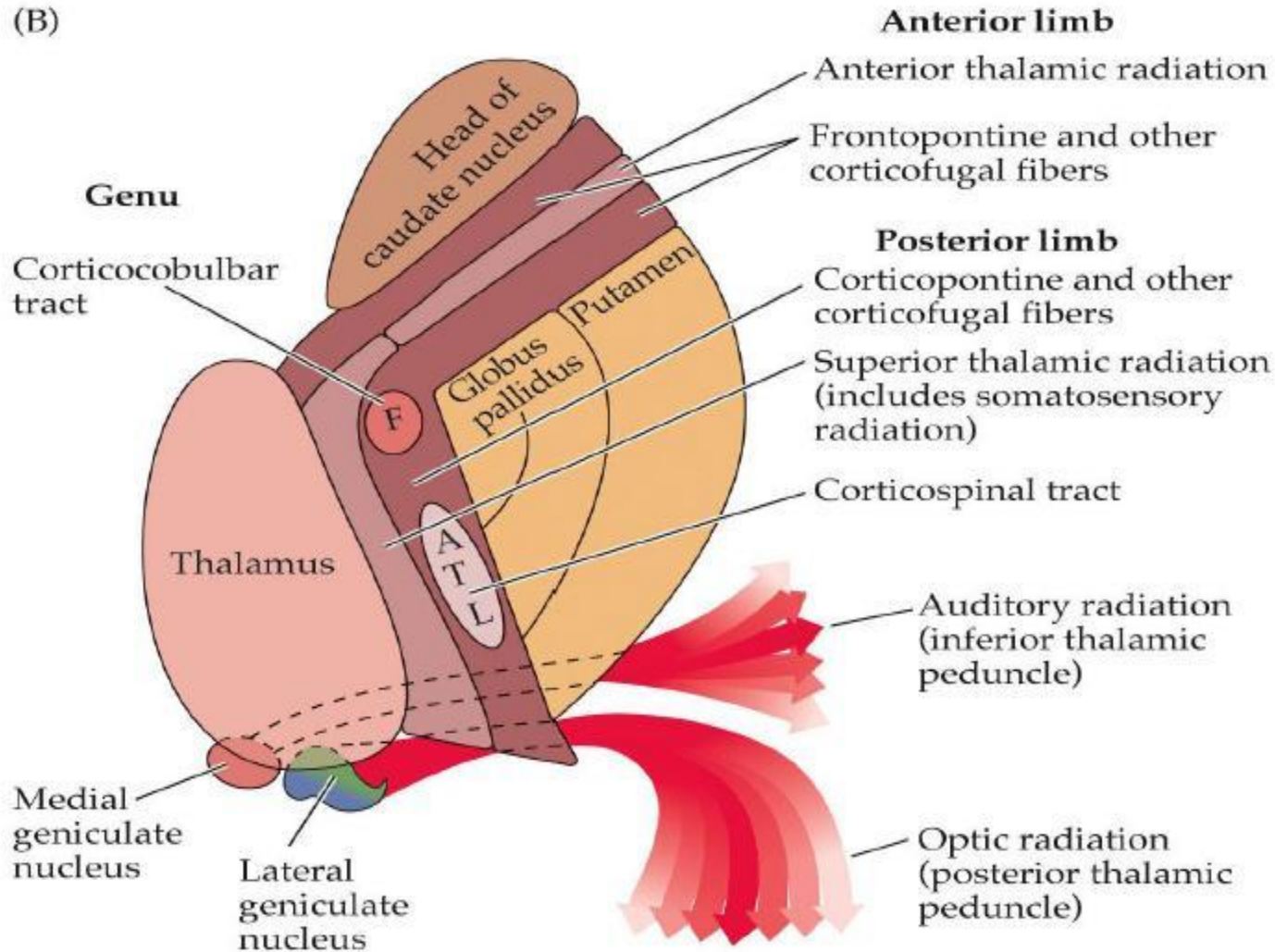

© 2002 Sinauer Associates, Inc.

**Figure showing Corticospinal & Corticobulbar Fibers in Internal capsule**

# Blood supply of the internal capsule

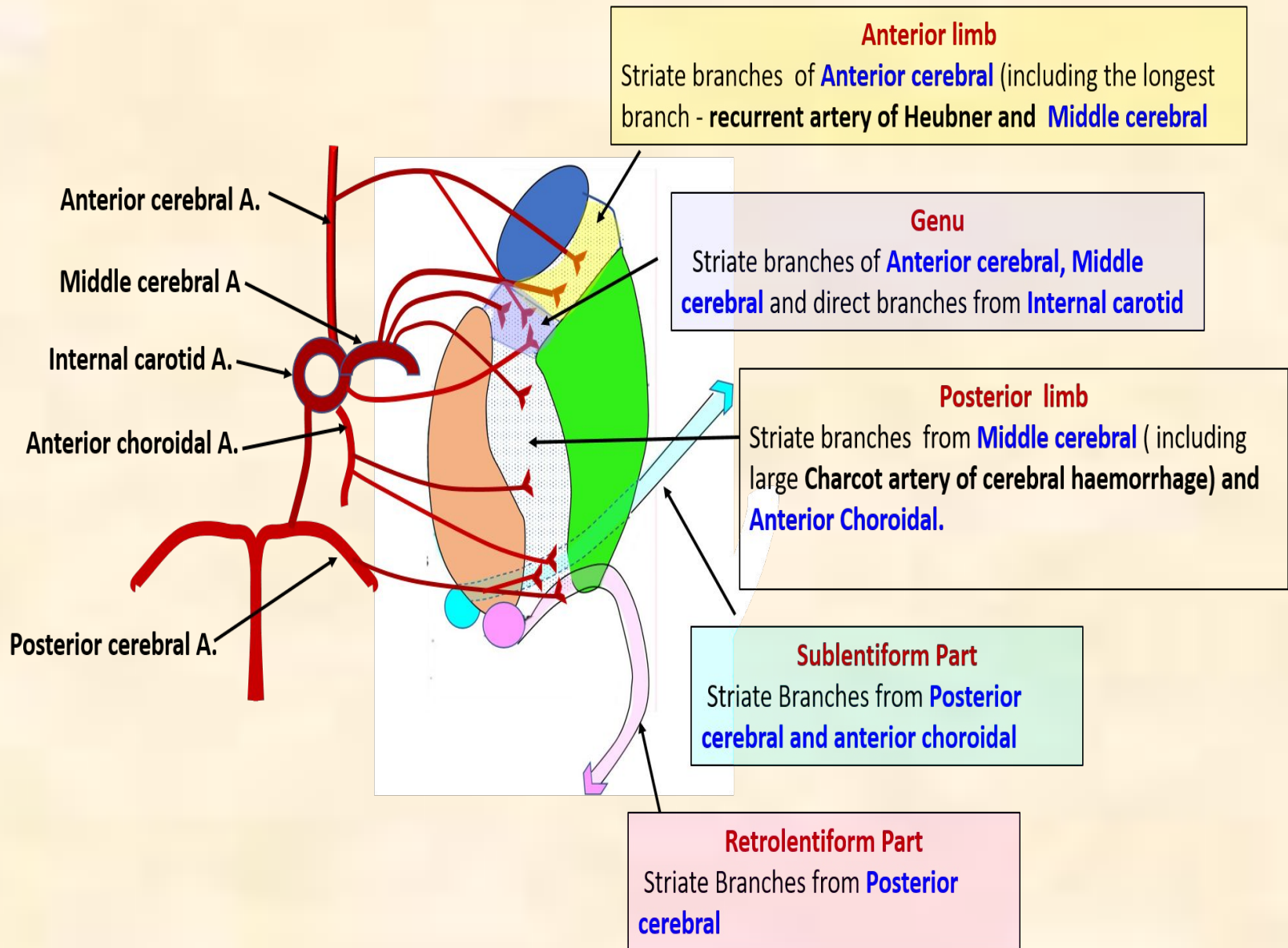

# The Human Basal Ganglia

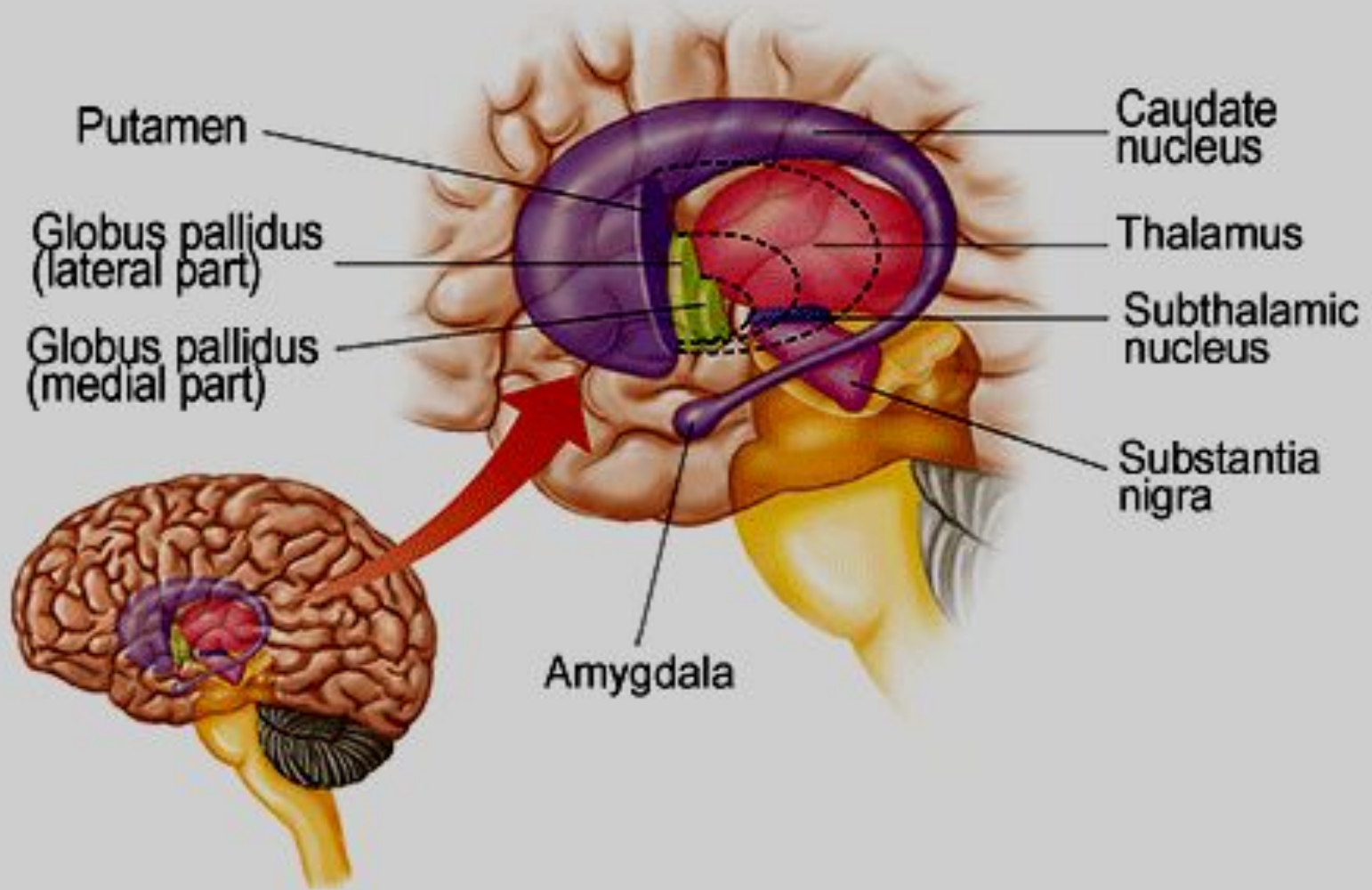

# FUNCTION OF BG

## •Voluntary movement

- Initiation of movement
- Change from one pattern to other
- Programming and correcting movement while in progress
- Learning skills (football,drawing,singing,...)

## •Postural control

- Automatic associated movement (walking, dancing)
- Control axial and girdle movements

**No direct connection with spinal cord or brain stem**

# SUBDIVISION OF BG

## A. Neostriatum or Striatum

Putamen

Caudate nucleus

## B. Pallio striatum or Pallidum

Globus pallidus

## C. Lentiform nucleus

Putamen lateral

Globus Pallidus medial

## D. Archistriatum

Amygdala

## E. Substantia nigra

## F. Subthalamic nucleus

## G. Claustrum

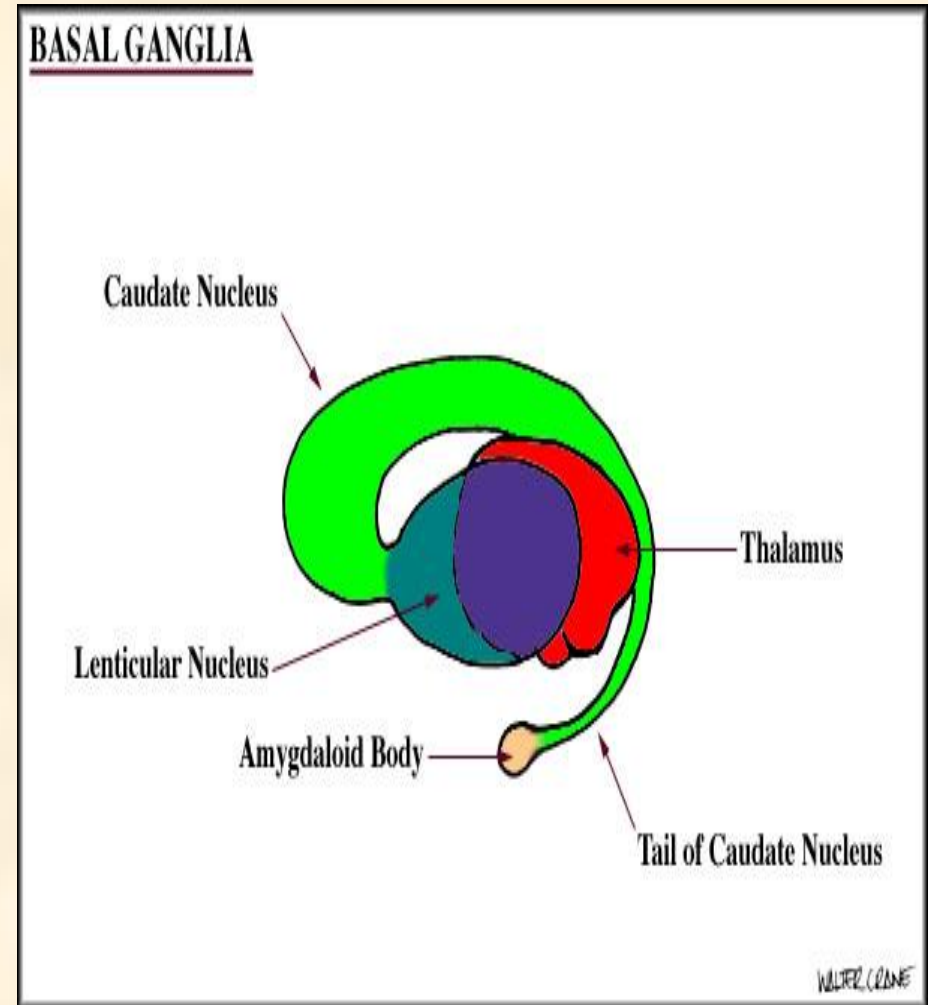

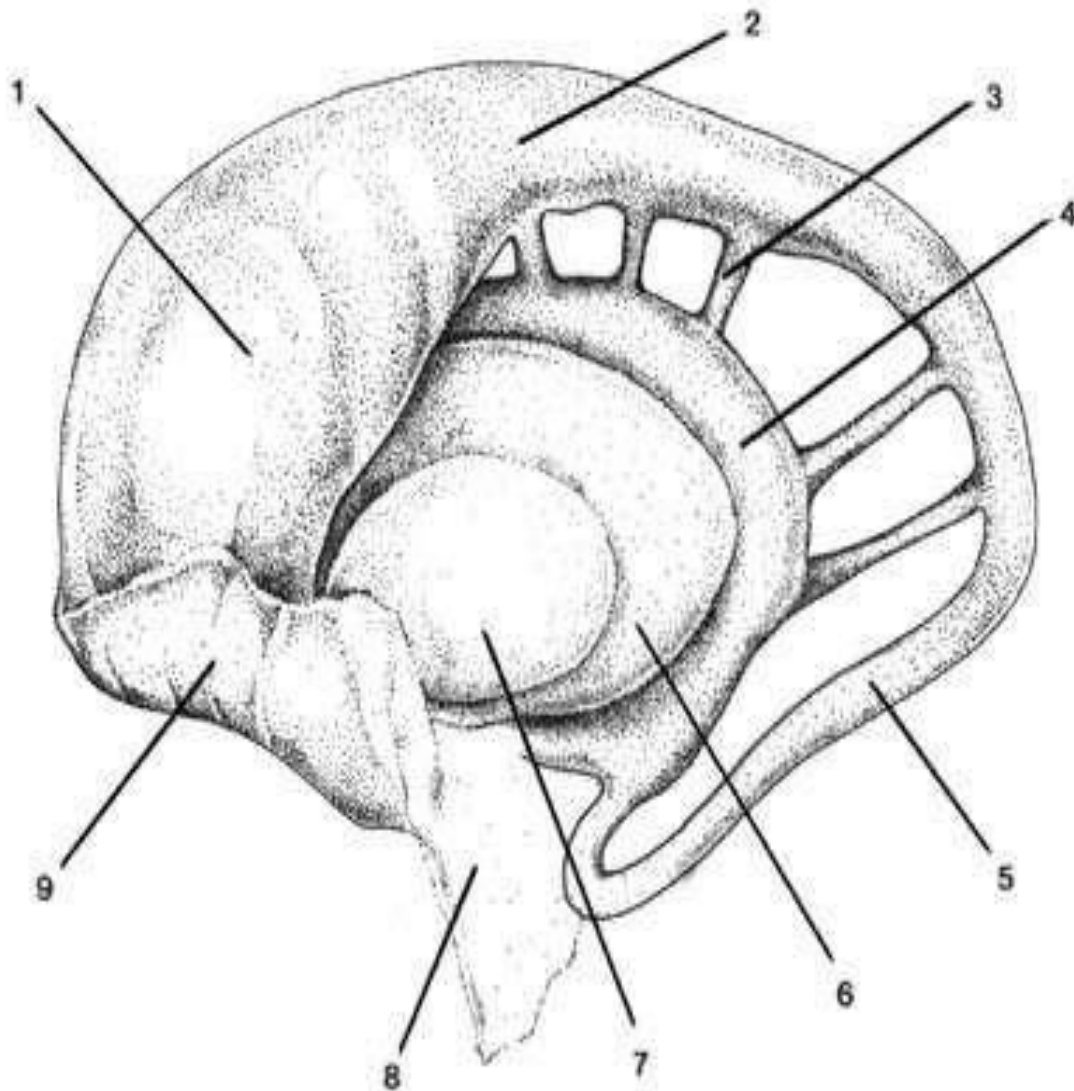

1. head of caudate nucelus
2. body ofcaudate nucelus
3. caudatolenticular gray bridge
4. putamen
5. tail of caudate nucleus
6. external segment of globus pallidus
7. internal segment of globus pallidus
8. amygdaloid body
9. nucleus accumbens septi

# Relation of the basal ganglia and the lateral ventricle

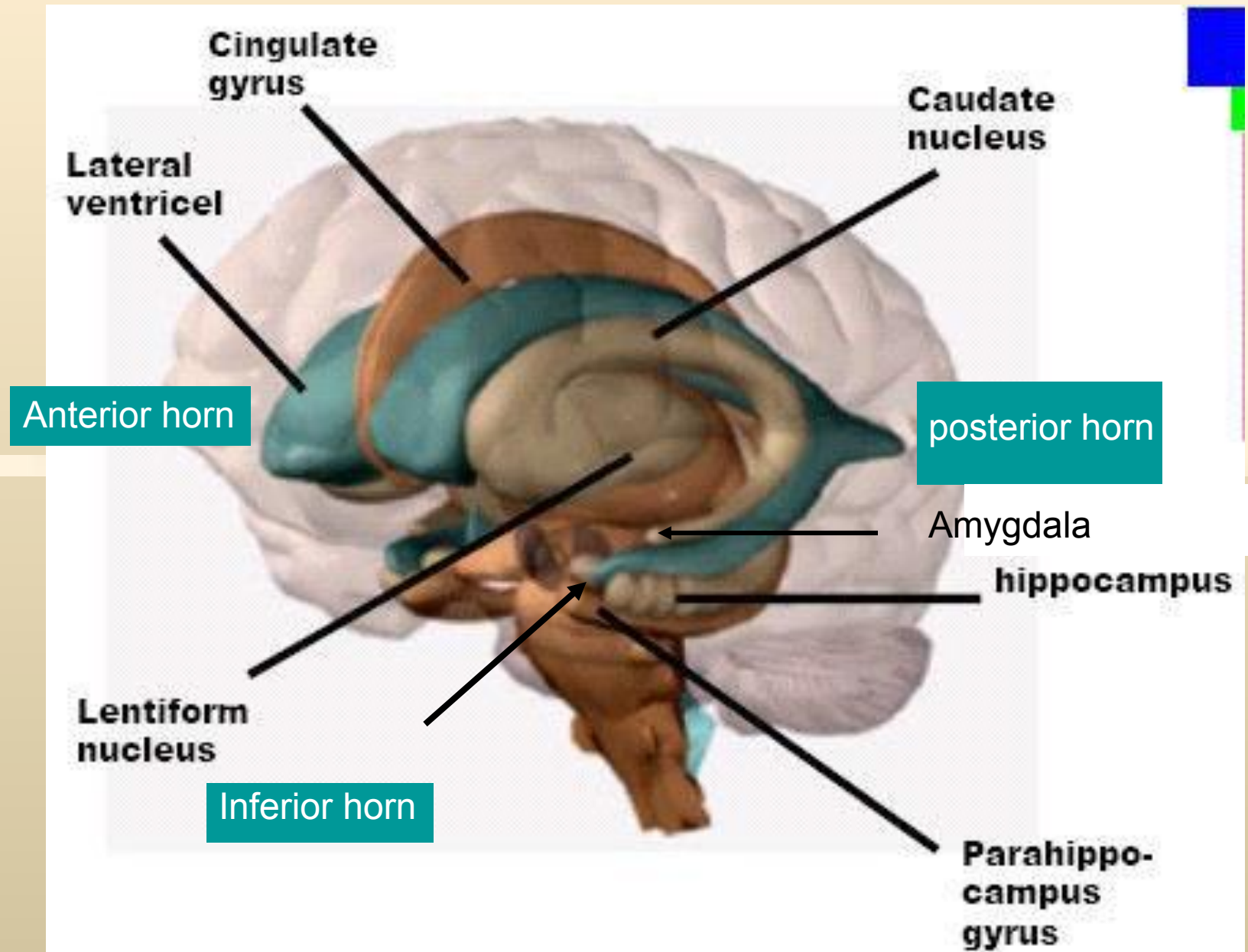

# Horizontal section , Basal ganglia and lateral ventricle

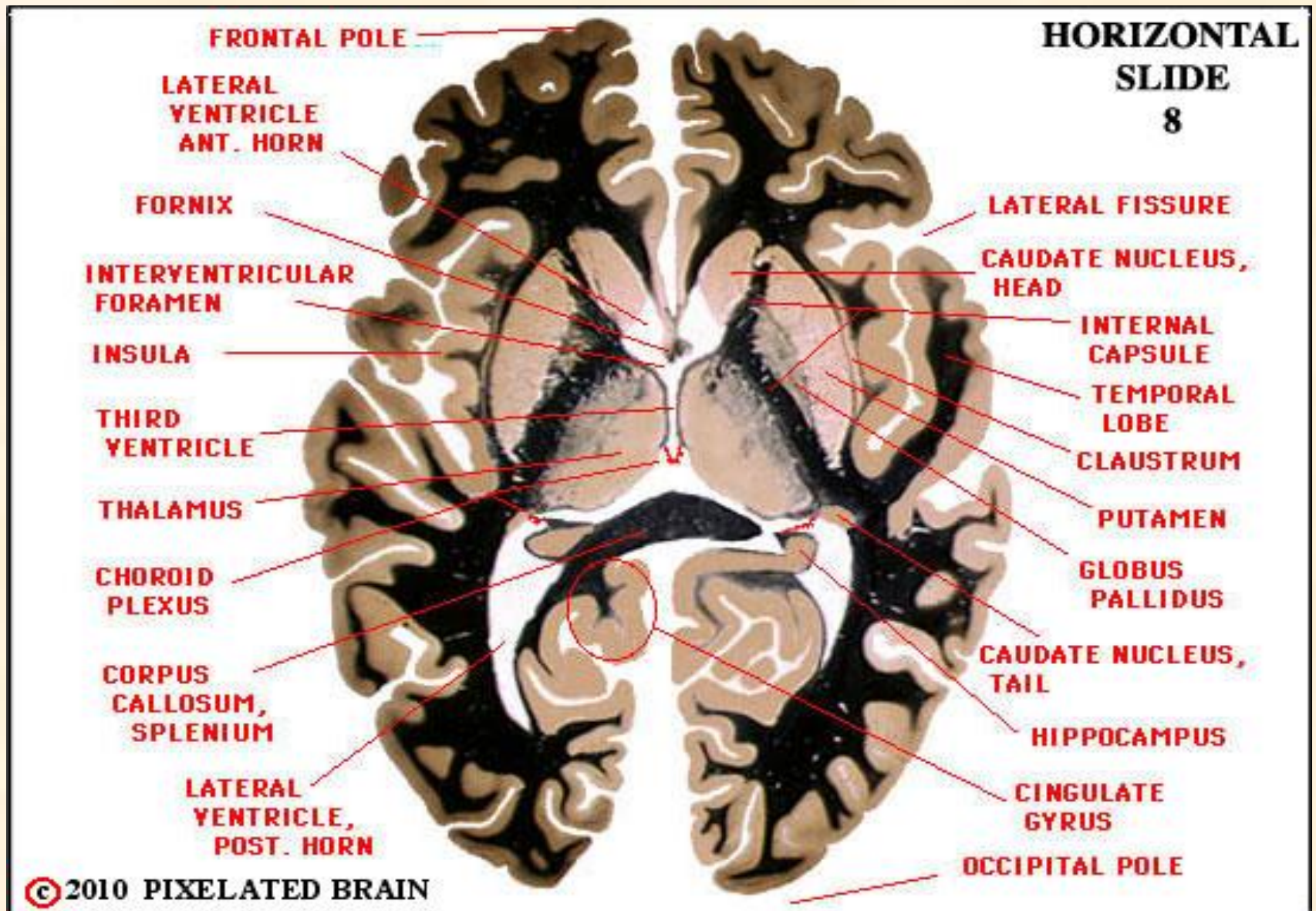

# Coronal section , Basal ganglia and lateral ventricle

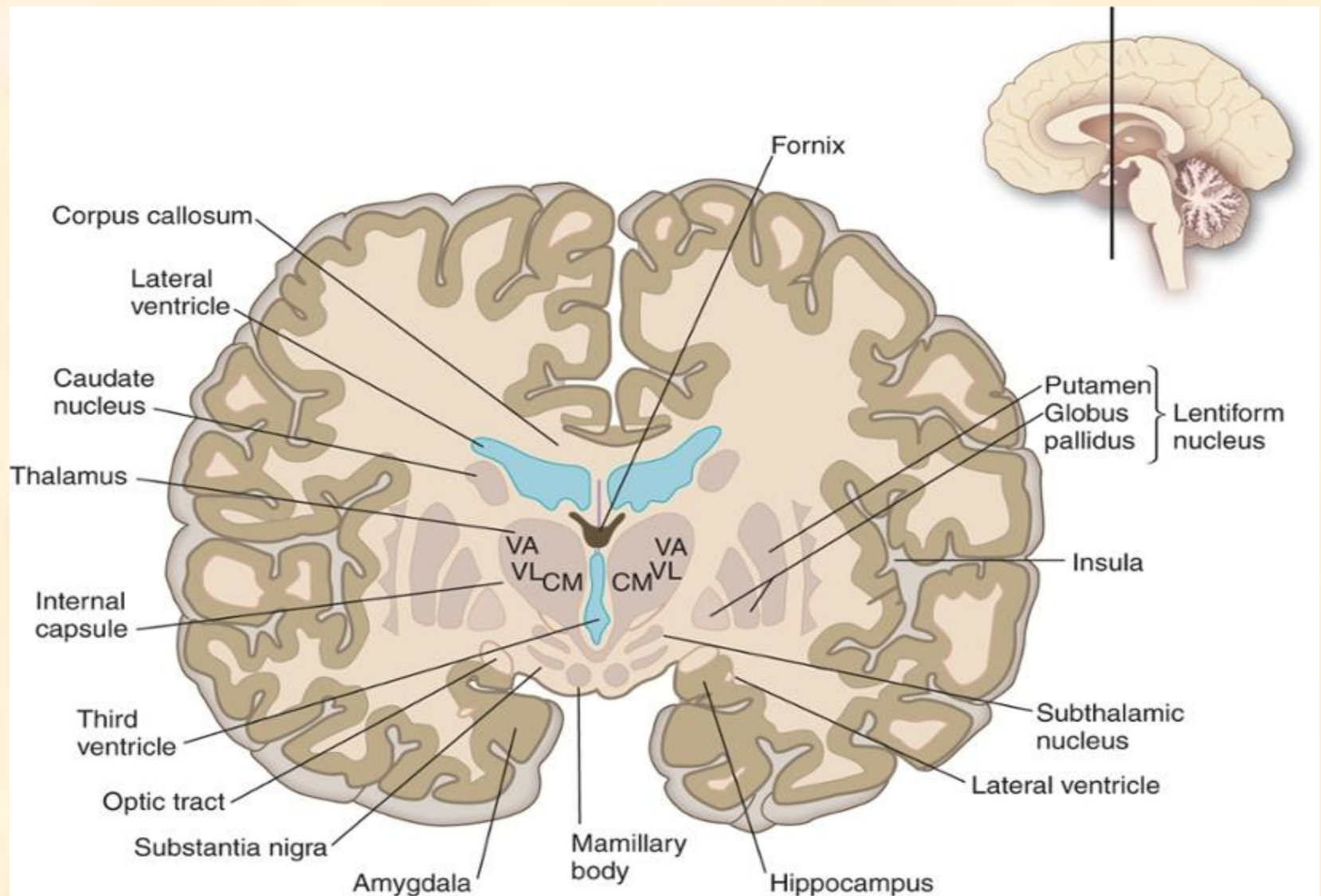

# Caudate nucleus

- C-shaped
- Head, body, tail
- Large head, tapering curved tail
- Head-frontal lobe
- Tail-occipital lobe
- End of tail-temporal lobe
  - -terminates in amygdaloid nucleus
  - (roof of inf horn of lateral ventricle)

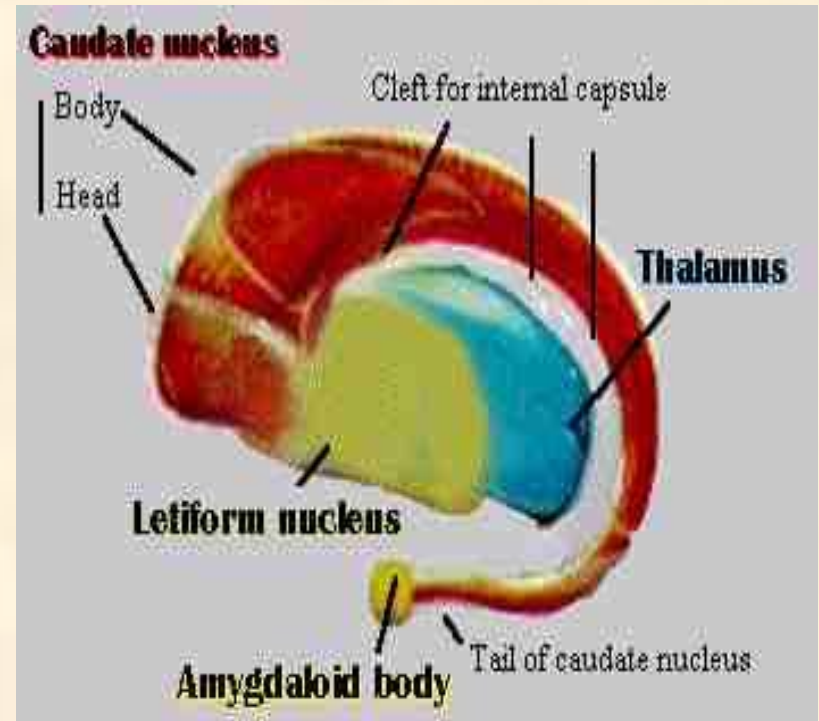

**Head Lies in the floor and lateral wall of anterior horn of the lateral ventricle**

**Body forms the floor of central part of lateral ventricle**

**Tail lies in the roof of the inferior horn of lateral ventricle**

# Lentiform nucleus

- Lens like nucleus which consists of 2 parts: large lateral dark part called “putamen” & small medial pale part called “globus pallidus” which is subdivided into external and internal segments.
- It is surrounded by external capsule (laterally) separating it from claustrum & internal capsule (medially) separating it from thalamus and caudate nucleus.

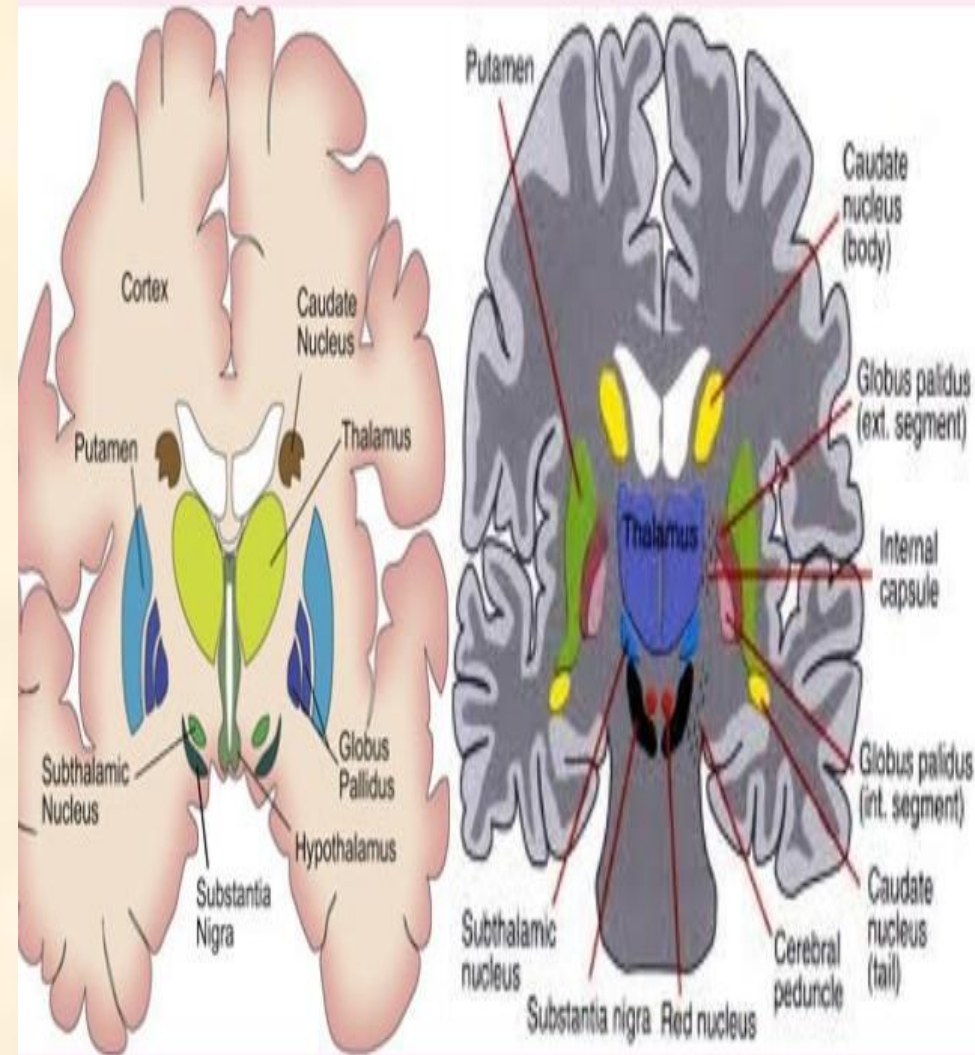

## Amygdaloid Nucleus

In the temporal lobe (uncus) connected to caudate tail.

Part of limbic system functionally.

Gives axons of stria terminalis that curves on superior surface of thalamus and ends in hypothalamus.

Sense of fear & smell function

## Substantia Nigra

Midbrain anterior to aqueduct

Substantia Nigra (pars compacta)  
(Dopamine/inhibitory)

Pars reticulata (output to brain)

## Subthalamic Nuclei

Diencephalon (Glutamine/excitatory)

## Clastrum

Lateral to lentiform & unknown function.

Lies between external and extreme capsules.

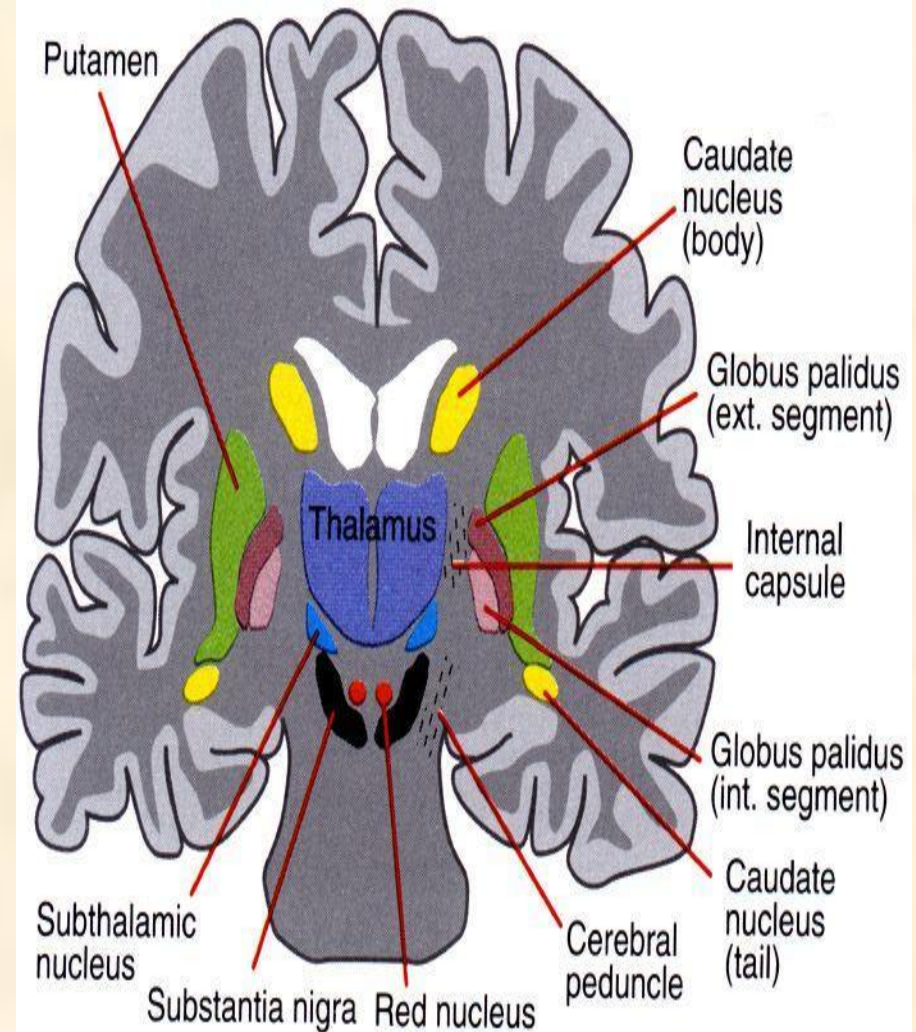

## Blood supply of BG

Anterior part of corpus striatum: **ACA**

Posterior part of corpus striatum: **MCA**

Tail of caudate and amygdaloid: **anterior choroidal of ICA**

# Connections

## **Receive input:**

Caudate nucleus

Putamen

(Corpus striatum)

## **Output leaves:**

Globus Pallidus

## Afferent

- **Corticostriate**  
Mostly from same side  
Sensory/Motor  
Glutaminergic++
- **Thalamostriate**
- **Nigrostriate**  
Dopaminergic—
- **Brainstem striatal fibres** Serotonin –
- **Subthalamic nucleus**
- **Mostly end in neostriatum except subthalamic N end in paleostriatum**

## Efferent

- **Striatopallidal**  
GABA—
- **Striatonigral**  
GABA, Acetylcholine, Substance P
- **Pallidofugal fibres (from GB)**
  - Ansa lenticularis** (thalamus)
  - Fasciculus lenticularis** (thalamus)
  - Subthalamic fasciculus** (subthalamus)
- **Pallidotegmental**  
Tegmentum of midbrain

# INTERNAL CONNECTIONS OF THE BASAL GANGLIA: DIRECT PATHWAY

**Read only**

# INTERNAL CONNECTIONS OF THE BASAL GANGLIA: INDIRECT PATHWAY

Read only

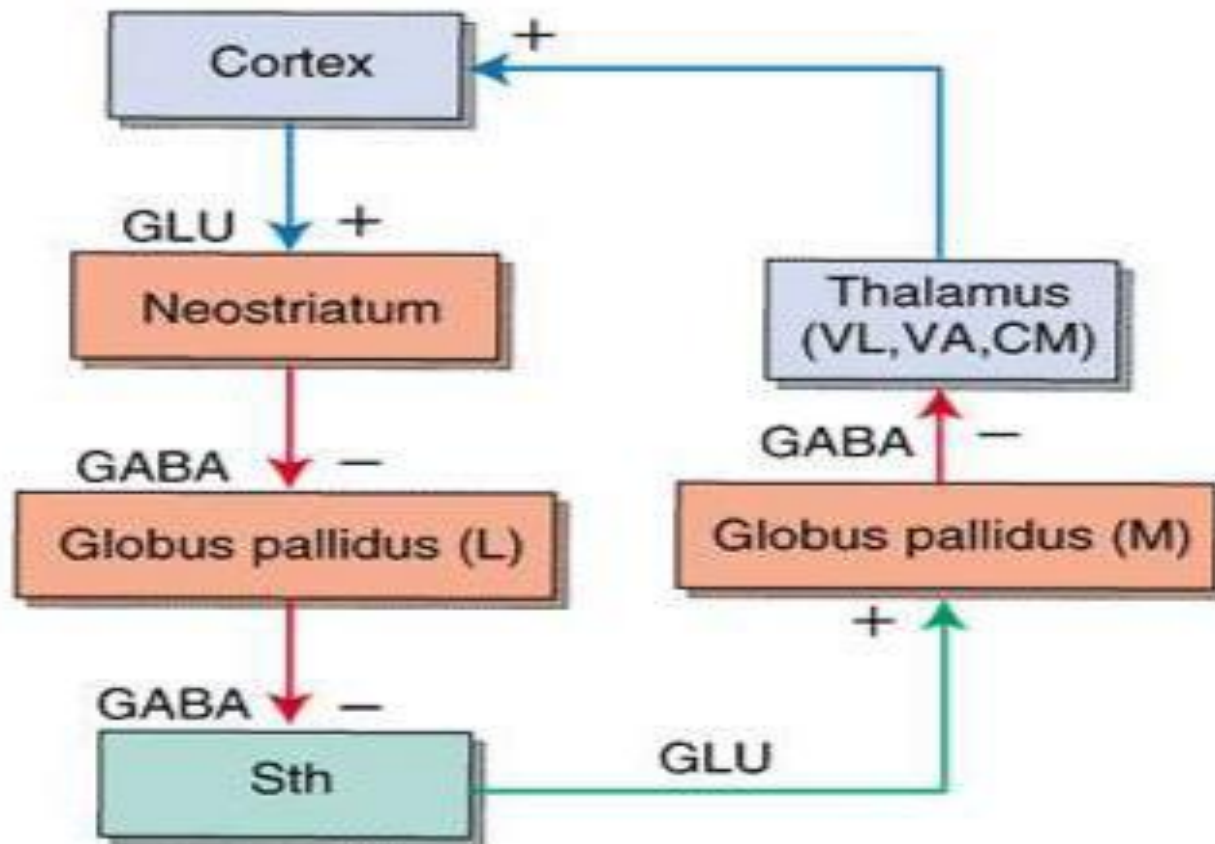

# Disease of basal ganglia

(on the opposite side)

## 1- Hypokinetic +hypertonia

- **Parkinsonism**
- **Lesion of direct pathway**
  - **Degeneration of dopamine**-producing cells in substantia nigra-depletion of dopamine in striatum
  - **Resting tremor** (N.B: intention tremor in cerebellar disease)
  - **Rigidity** – simultaneous contraction of flexors and extensors
  - **Bradykinesia** = Slowness of movement (slurred speech) and mask face
  - **Postural disturbance**
  - **No loss of motor or sensory function**
  - **Treated by L-Dopa not dopamine**



# Disease of basal ganglia

## 2- Hyperkinetic

(lesion of indirect pathway)

- **Huntington's disease (hypotonia+hyperkinesia)**
  - hereditary disease of unwanted movements. It results from degeneration of the caudate and putamen, and produces continuous dance-like movements of the face and limbs
    - choreoathetosis
- **Sydenham Chorea**

Rheumatic fever- transient- full recovery
- **Hemiballism**
  - flailing movements of one arm and leg (one-sided), which is caused by damage (i.e., stroke) of the subthalamic nucleus.

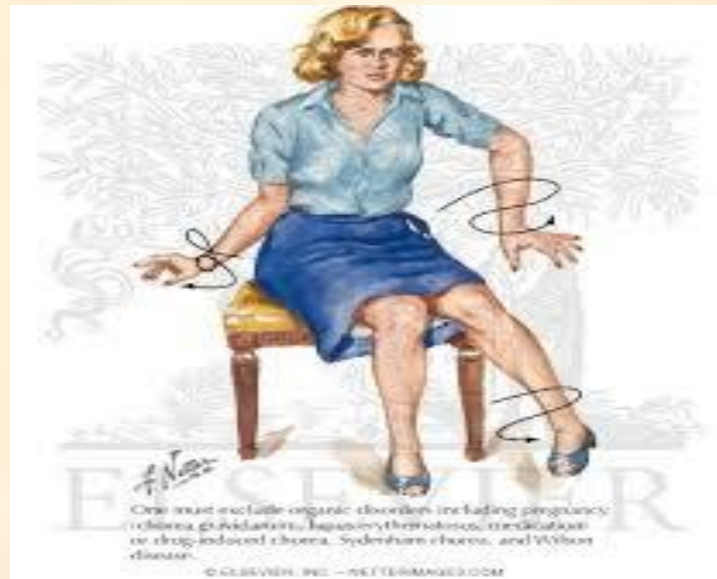

**Huntington's Chorea**

**Sydenham's chorea**



**hemiballismus**

# Normal Basal Ganglia circuit

Read only

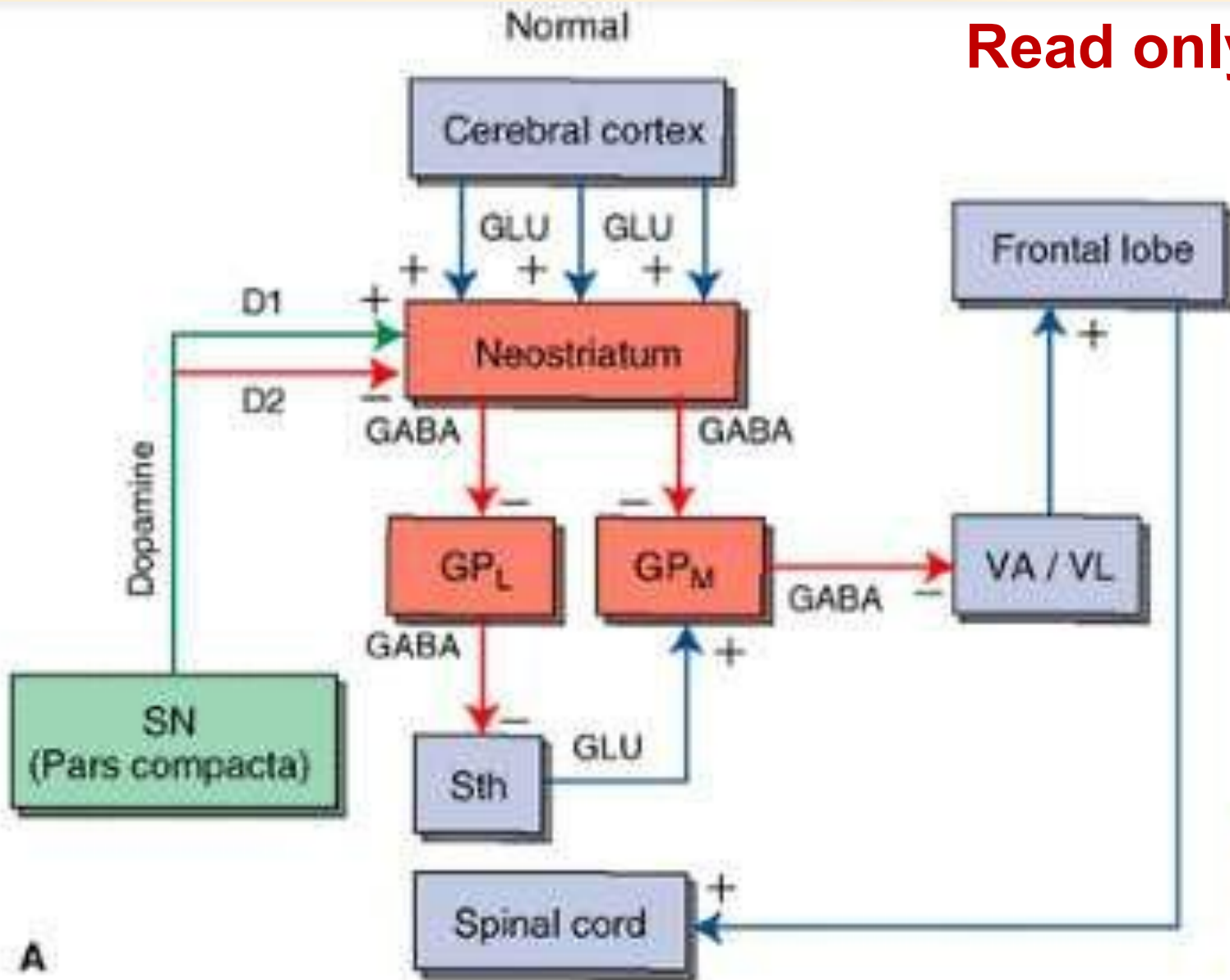

# Parkinson's Disease – Hypokinetic Disorder

Read only

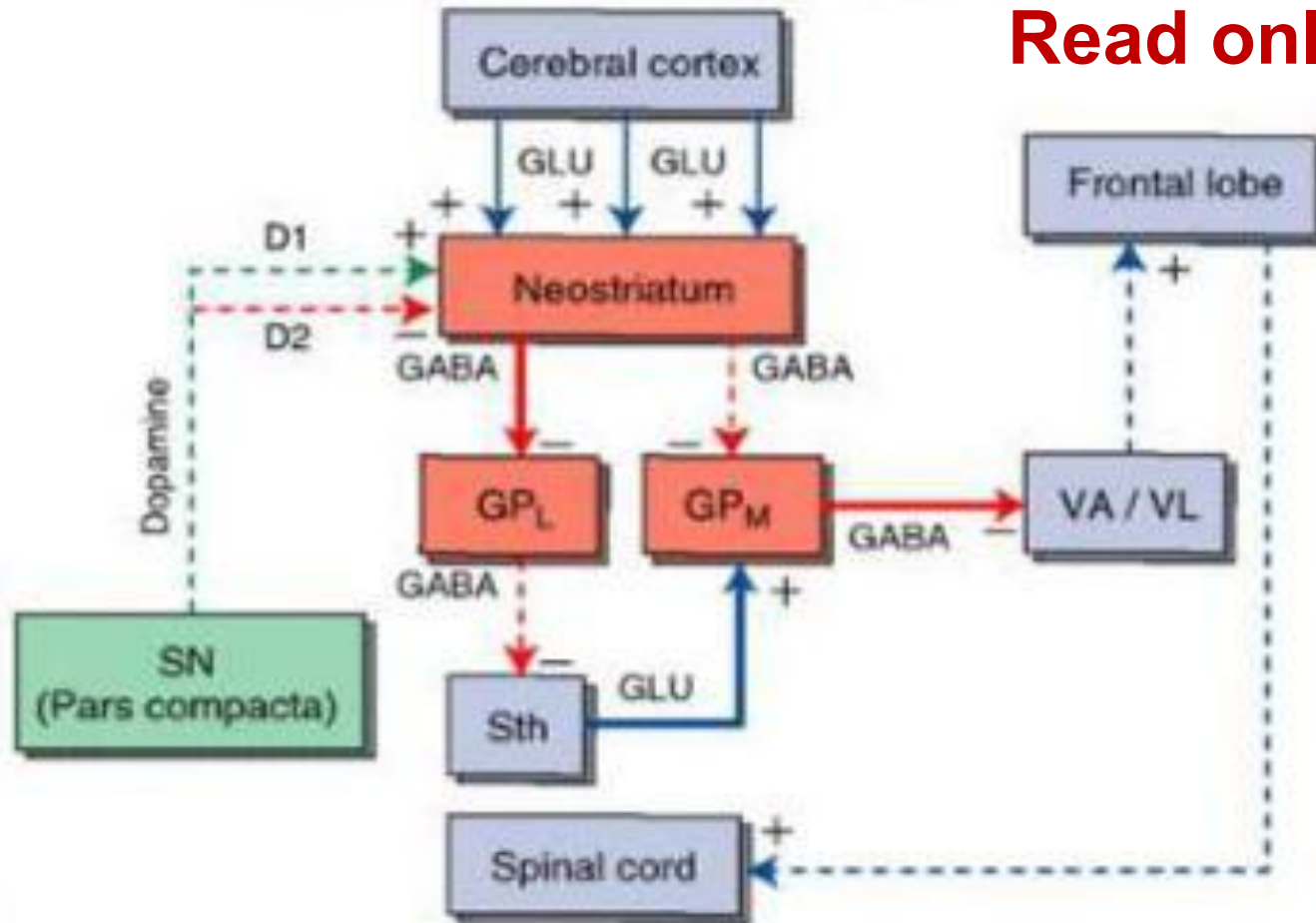

B



# Huntington's Disease – Hyperkinetic Disorder

Read only

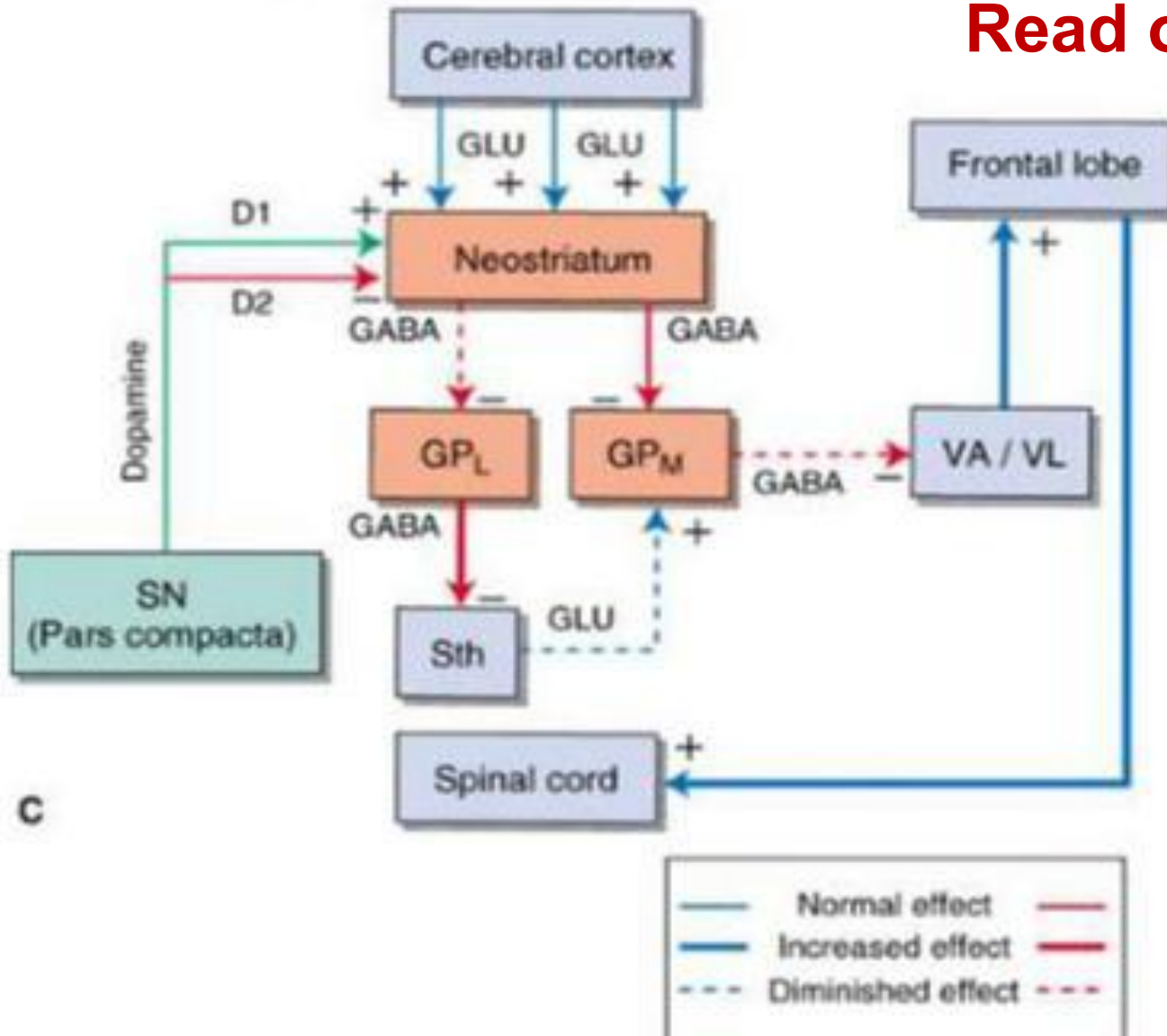

C



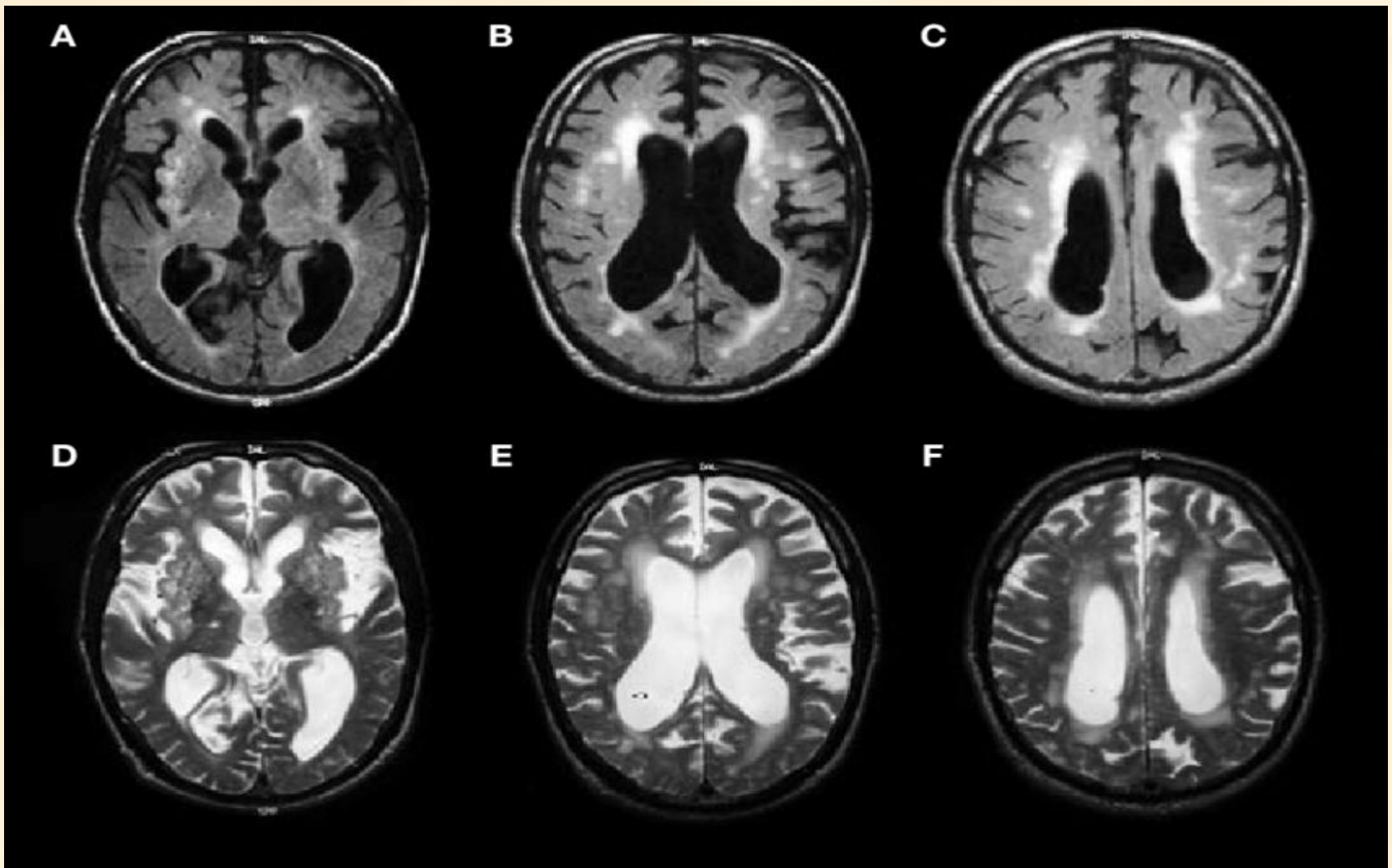

Brain MRI scans of a patient with suspected vascular parkinsonism. Axial fluid-attenuated inversion recovery (A-C). MRI scans of the basal ganglia (A,D). The increased periventricular and subcortical white matter signal is suggestive of small-vessel ischemic disease. The mild ventricular dilatation is roughly proportionate to the apparent degree of cortical atrophy.

**THANK YOU**