

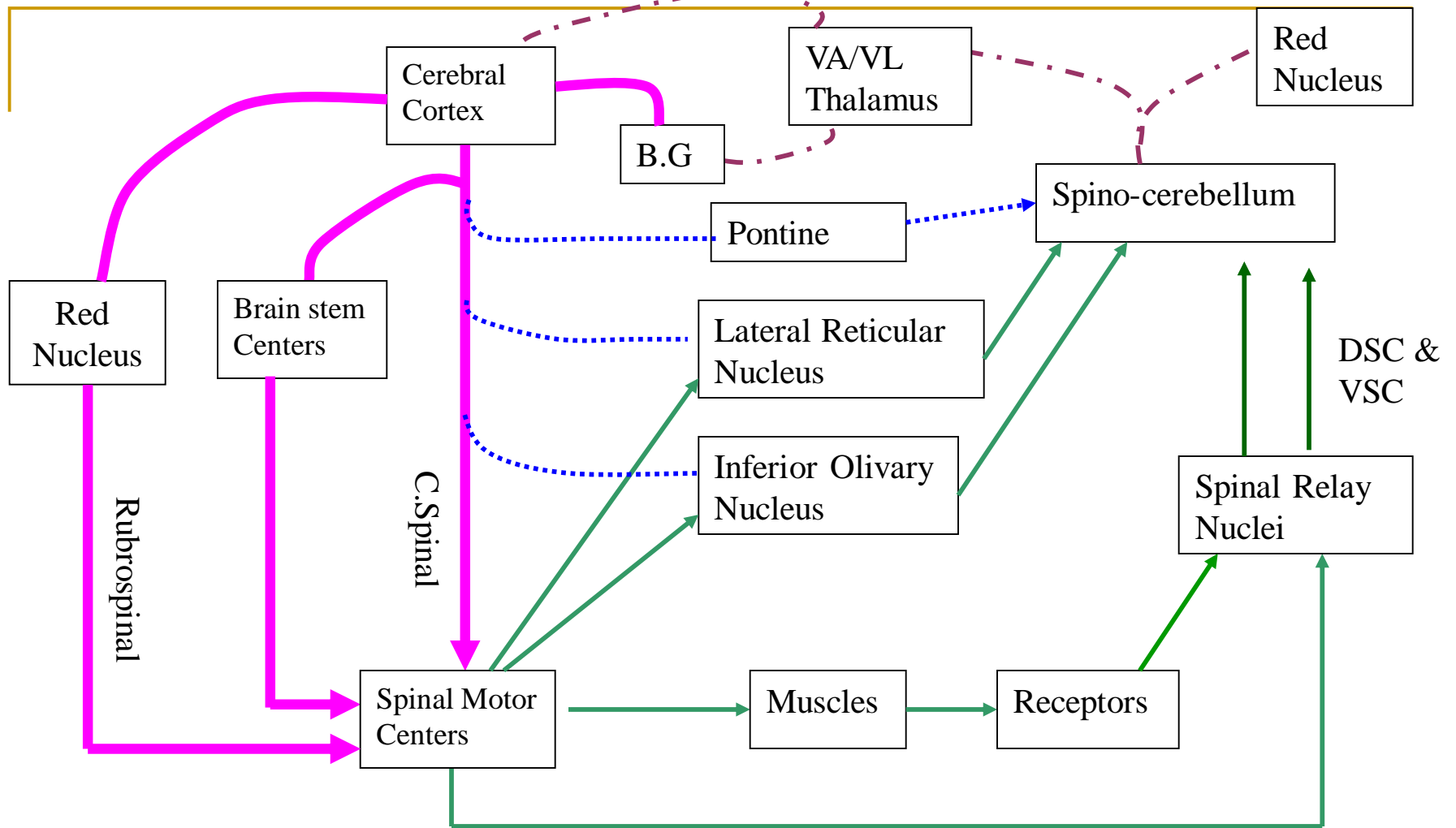



Brainstem Motor Function-

Faisal I. Mohammed, MD, PhD

Objectives

- Describe the general functions of the brainstem
- List the descending brainstem tracts
- Explain how these tracts work to control motor movements
- Outline some brainstem abnormalities



-  Motor Command
-  Feed Back
-  Command Monitor
-  Corrective Command

Motor System

Control of Motor Function by the Brainstem

- Brainstem as an extension of the spinal cord.
 - performs motor and sensory functions for the face and head (i.e., cranial nerves).
 - similar to spinal cord for functions from the head down.
- Contains centers for stereotypic movement and equilibrium.

Support of the Body Against Gravity

- The muscles of the spinal column and the extensor muscles of the legs support the body against gravity.
- These muscles are under the influence of brainstem nuclei.
- The pontine reticular nuclei excite the antigravity muscles.
- The medullary reticular nuclei inhibit the antigravity muscles.

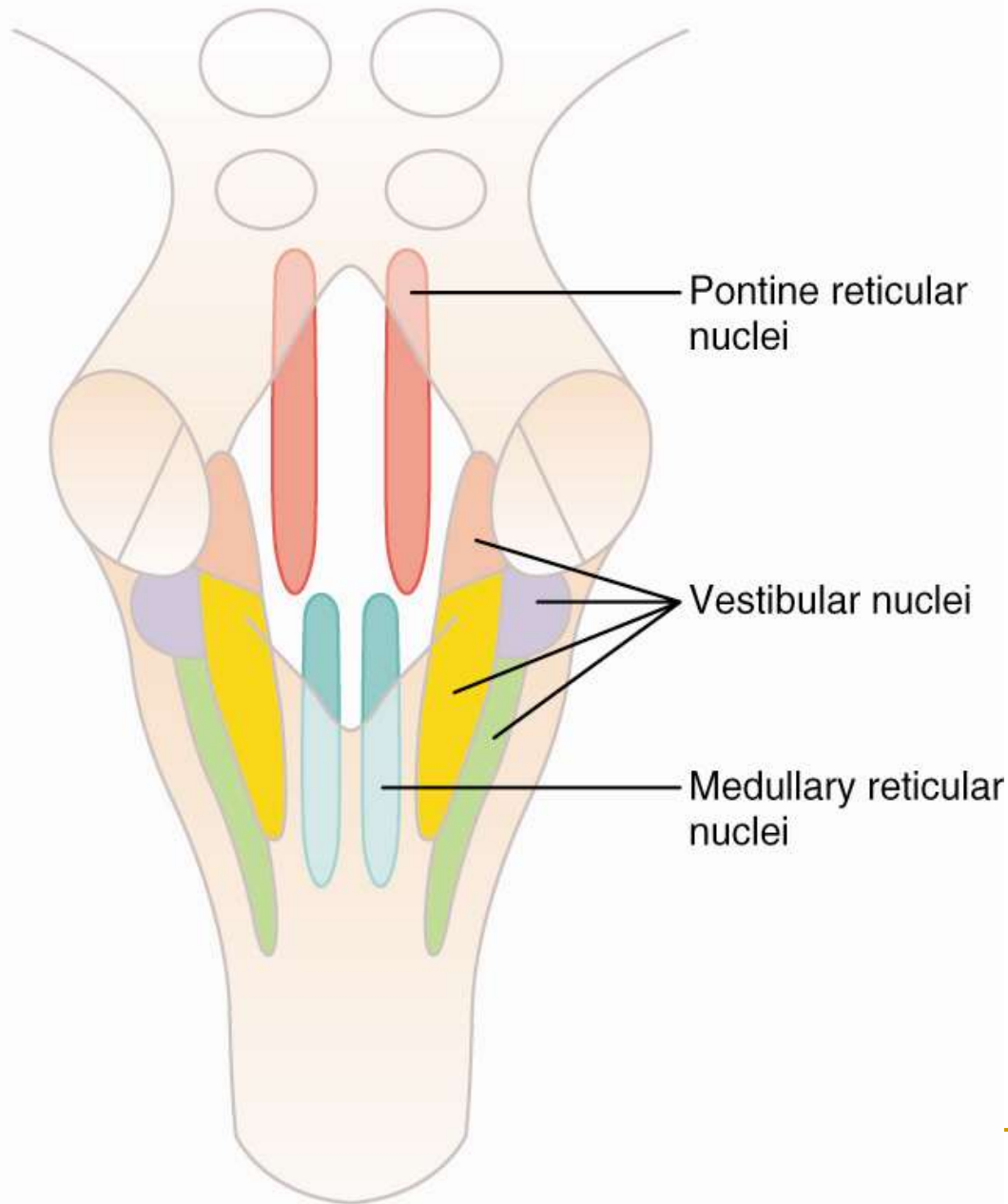

Orientation of the Pontine and Medullary Reticular Nuclei

Pontine Reticular Nuclei

- Transmit excitatory signals through *pontine reticulospinal tract*.
- Pontine reticular nuclei have a high degree of natural excitability, *they are intrinsically active*.
- When unopposed they cause powerful excitation of the antigravity muscles.

Extrapyramidal Tract Pathways

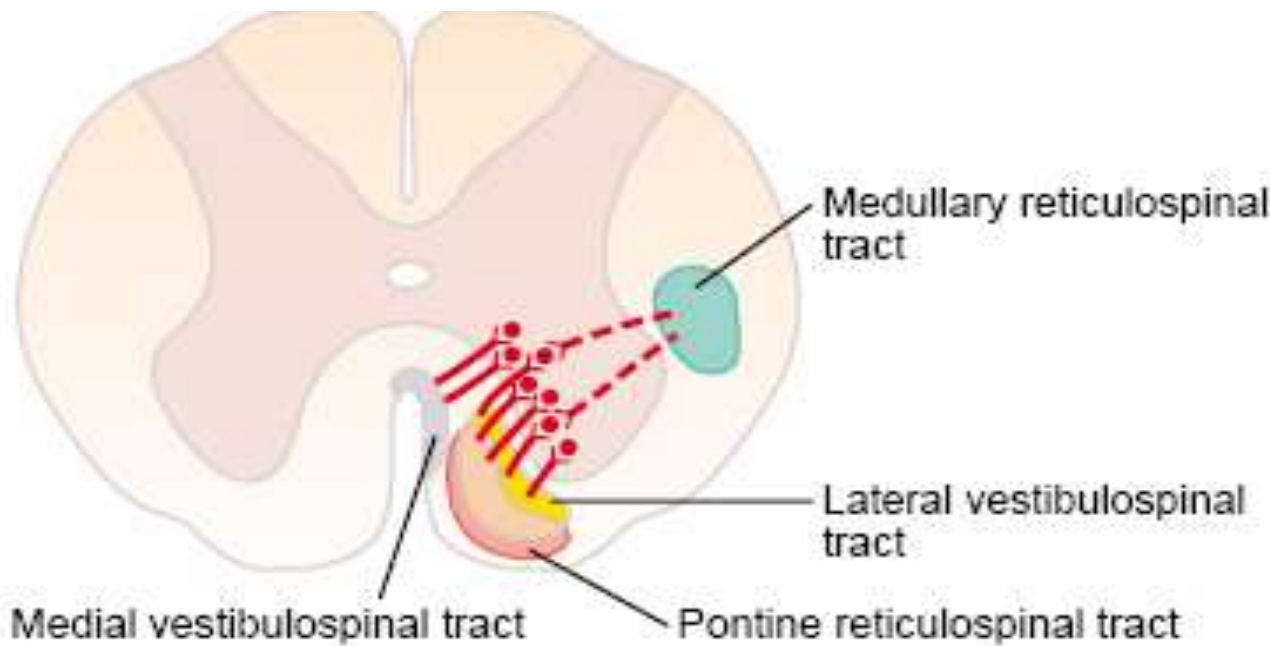

Figure 55-8

Vestibulospinal and reticulospinal tracts descending in the spinal cord to excite (*solid lines*) or inhibit (*dashed lines*) the anterior motor neurons that control the body's axial musculature.

Lateral system

Pathways: excites

Flexors; Lateral

Corticospinal,

Rubrospinal, medullary

reticulospinal

Medial system

pathways: Excites

extensors; Pontine

reticulospinal,

lateral and medial

vestibulospinals

Medullary Reticular Nuclei

- Transmit inhibitory signals to the antigravity muscles through the *medullary reticulospinal tract*.
- These nuclei receive collateral input from the corticospinal tract, rubrospinal tract, and other motor pathways. Cortico-medullary input excites this tract.
- These systems can activate the inhibitory action of the medullary reticular nuclei and counterbalance the signals from the pontine reticulospinal.
- Decerebrate rigidity- removal of the cortical control over the medullary reticulospinal keeps pontine reticulospinal unchecked leads to hyperactivity of anti-gravity muscles.

Vestibular Apparatus

- System of bony tubes and chambers in the temporal bone:
 - semicircular ducts
 - utricle
 - saccule
- Within the **utricle** and the **saccule** are sensory organs for detecting the orientation of the head with respect to gravity (linear acceleration) called the *macula*.

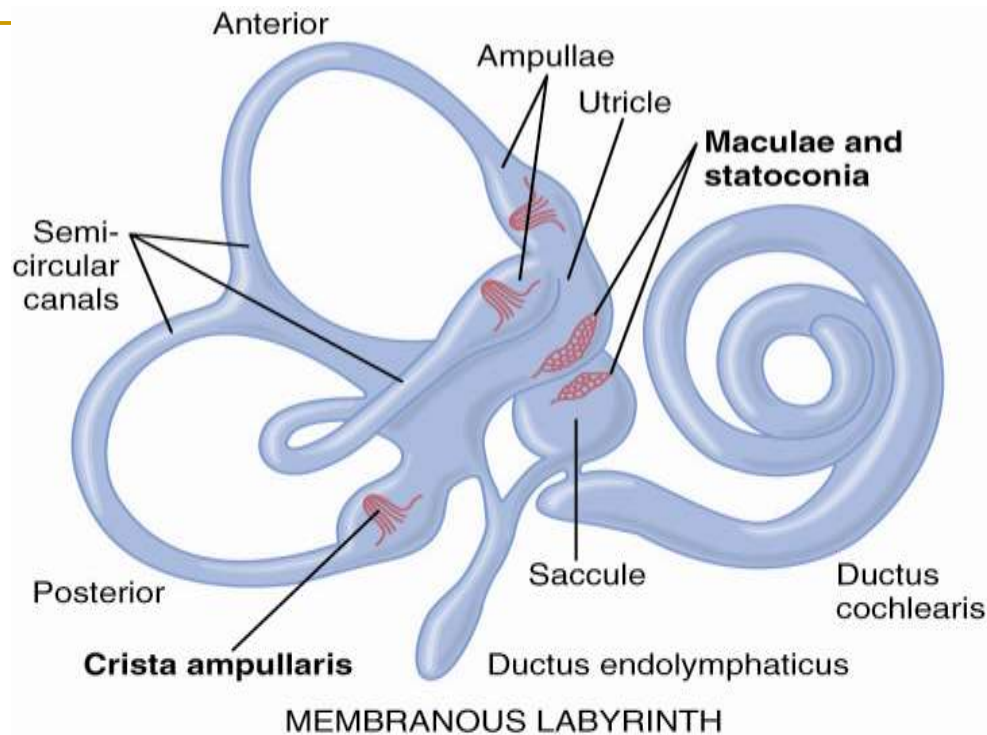

The Vestibular Apparatus

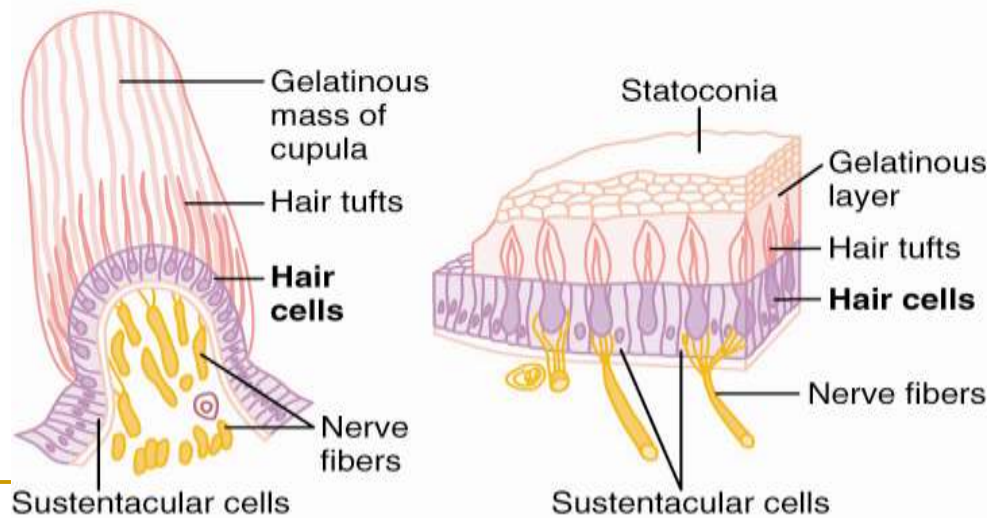

CRISTA AMPULLARIS AND MACULA

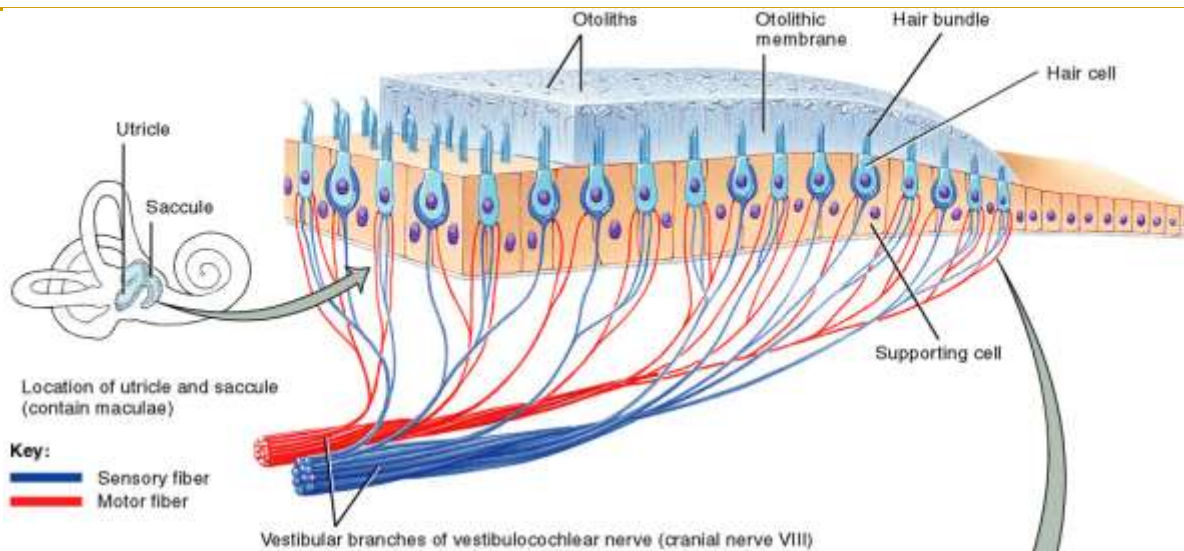

(a) Overall structure of a section of the macula

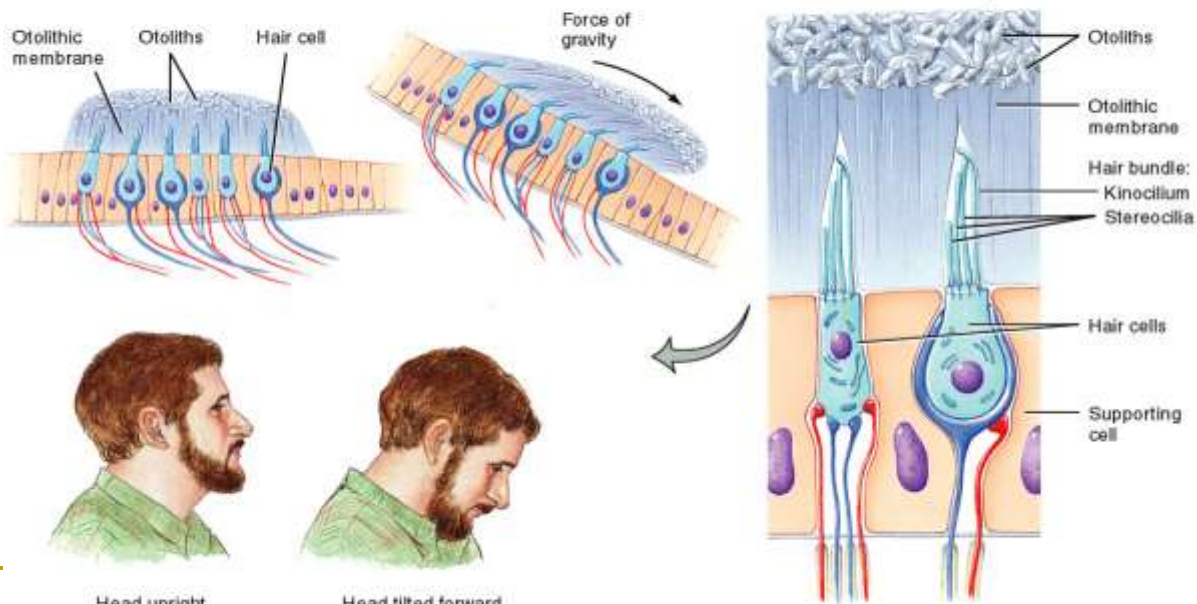

(c) Position of macula with head upright (left) and tilted forward (right)

(b) Details of two hair cells

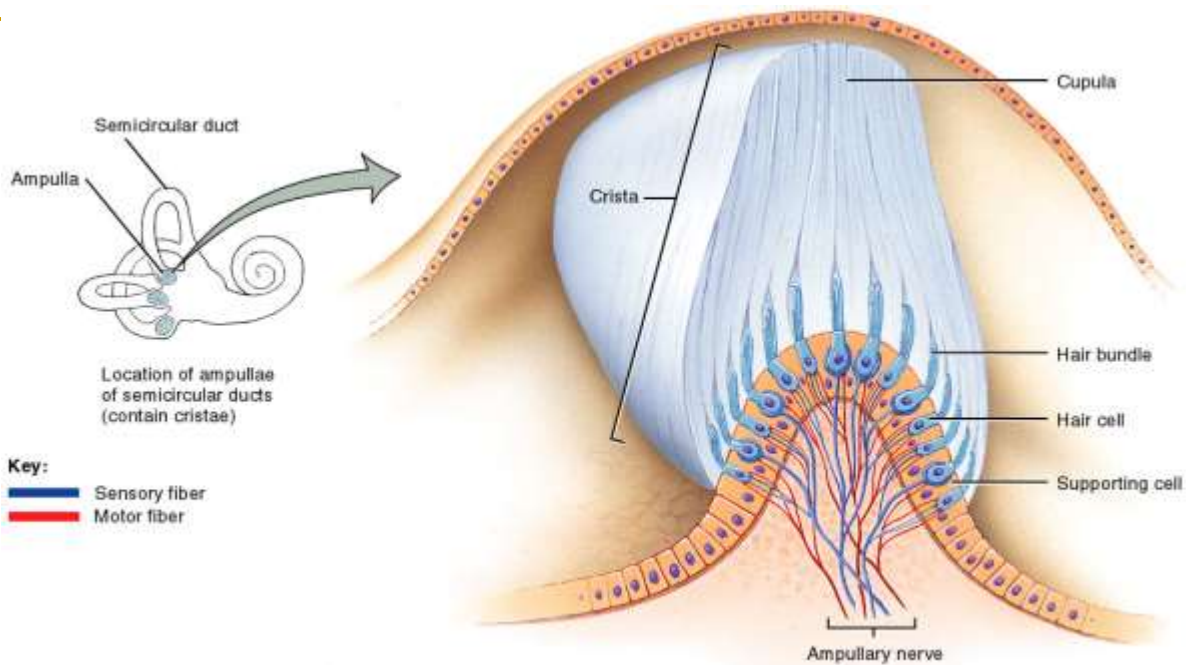

(a) Details of a crista

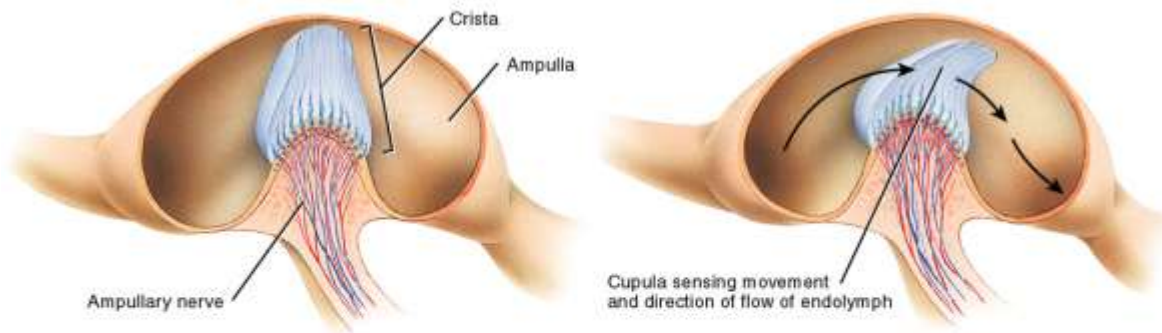

Head in still position



Head rotating

(b) Position of a crista with the head in the still position (left) and when the head rotates (right)

The Macula

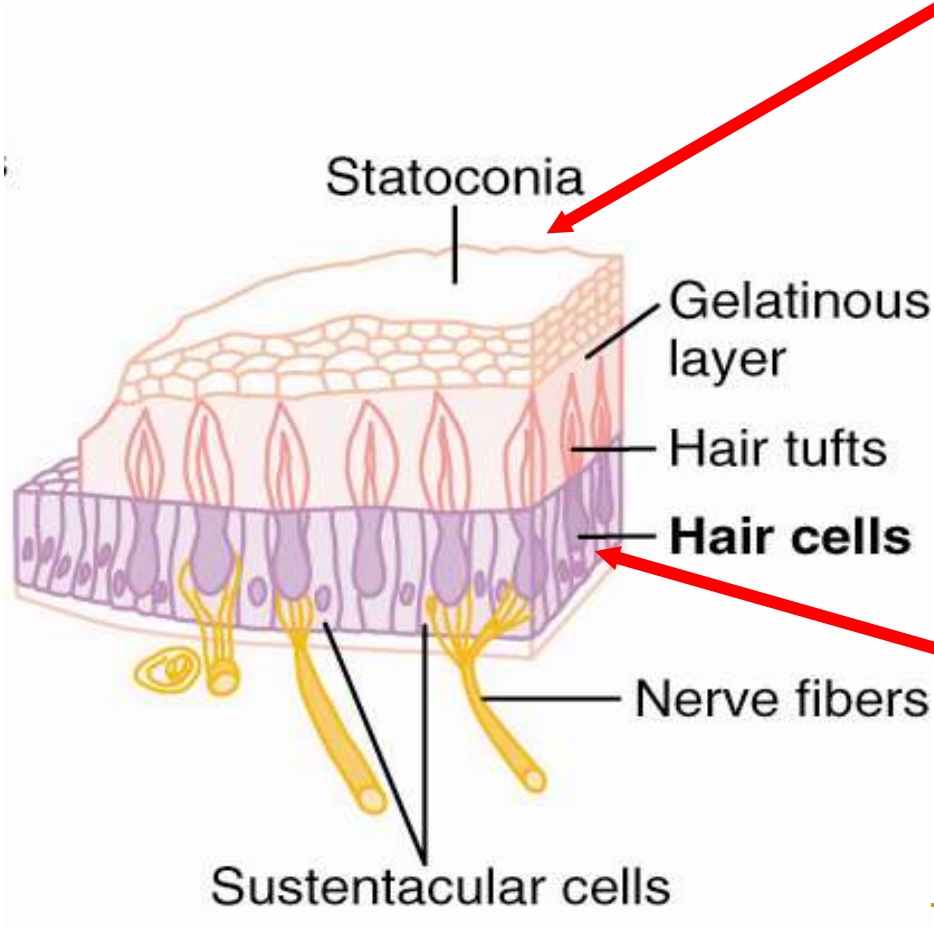

The statoconia make the structure *top heavy* so that it is capable of responding to changes in head position.

Gravity sensitive receptor consists of gravity sensitive hair cells.

Hair Cells

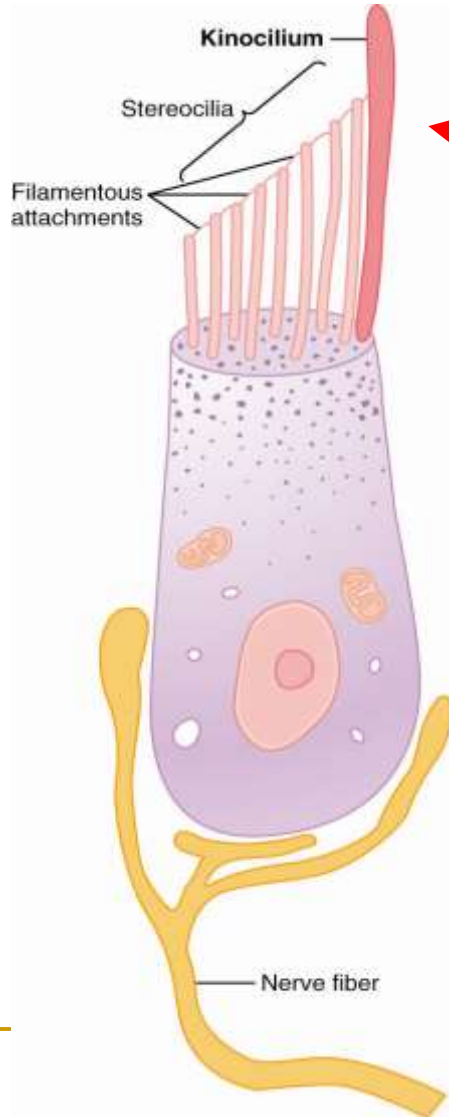

Have a series of protrusions called *stereocilia* and one large protrusion called the *kinocilium*. These structures are directionally sensitive.

Bending in one direction causes depolarization, bending in the opposite direction cause hyperpolarization.

Detection of Head Orientation

- In each macula different hair cells are oriented in different directions.
- Some are stimulated when the head bends forward, some when the head bends backward, some when the head bends to the side.
- The pattern of excitation of the hair cells appraises the brain of the orientation of the head with respect to gravity (linear acceleration)

Semicircular Canals

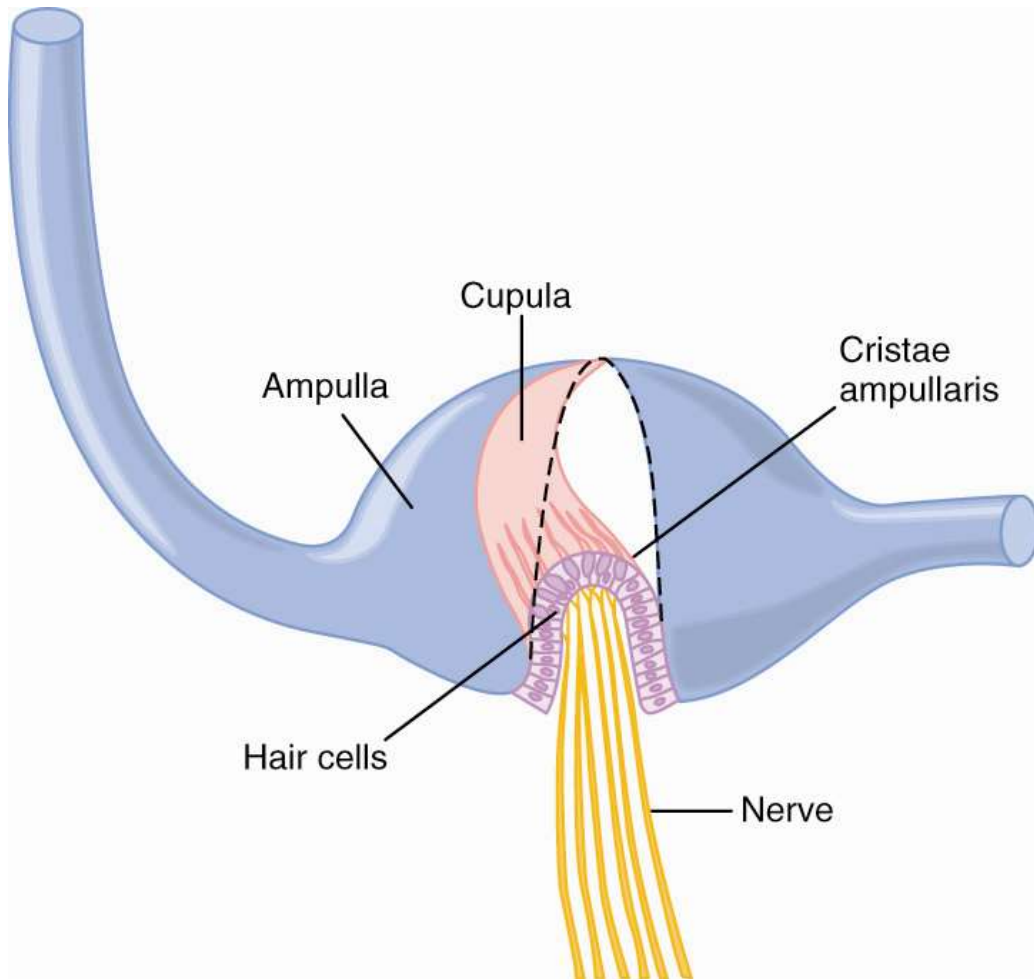

- All located at 90° to each other representing all 3 planes in space. (lateral or horizontal, anterior and posterior)
- Each duct has an enlargement at the end called an *ampulla*.
- Within the ampulla is a sensory structure called the *crista ampullaris*.
- Bending the crista ampullaris in a particular direction excites the hair cells

Maintaining Equilibrium

- Information from the hair cells in the maculae of the utricles and saccules is transmitted to the brain via the vestibular nerve.
- When the body is accelerated forward the hair cells of the maculae bend in the opposite direction, this causes one to feel as if they are falling backward.
- Reflexes cause the body to lean forward.

Semicircular Ducts Detect Angular Acceleration

- Rotation of the duct detects rotational movements of the head (rotational acceleration)
- Endolymph tends to remain stationary in the duct because of inertia.
- Rotation of the duct in one direction causes relative movement of endolymph in the opposite direction activating the receptors in the crista ampullaris.
- Stop the rotation, the opposite happens.

Response of a Hair Cell When a Semicircular Canal is Stimulated

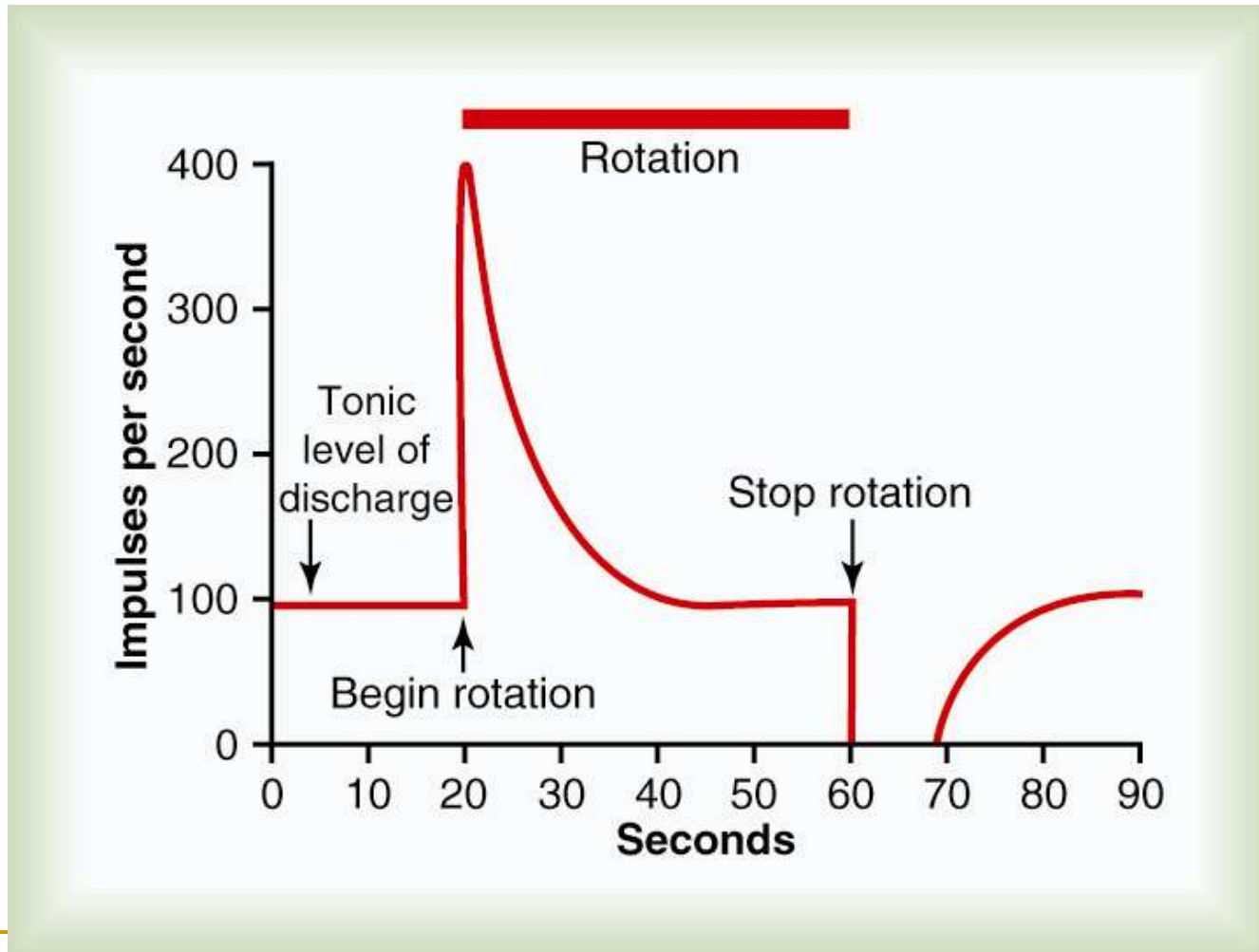

Predictive Function of the Semicircular Ducts

- Semicircular ducts predict situations in which equilibrium will be affected and this information is sent to the brain.
- Corrective measures are initiated before the equilibrium is affected.
- Neck proprioceptors and visual input also contribute to the maintenance of equilibrium.

Neuronal Connections of the Vestibular Apparatus

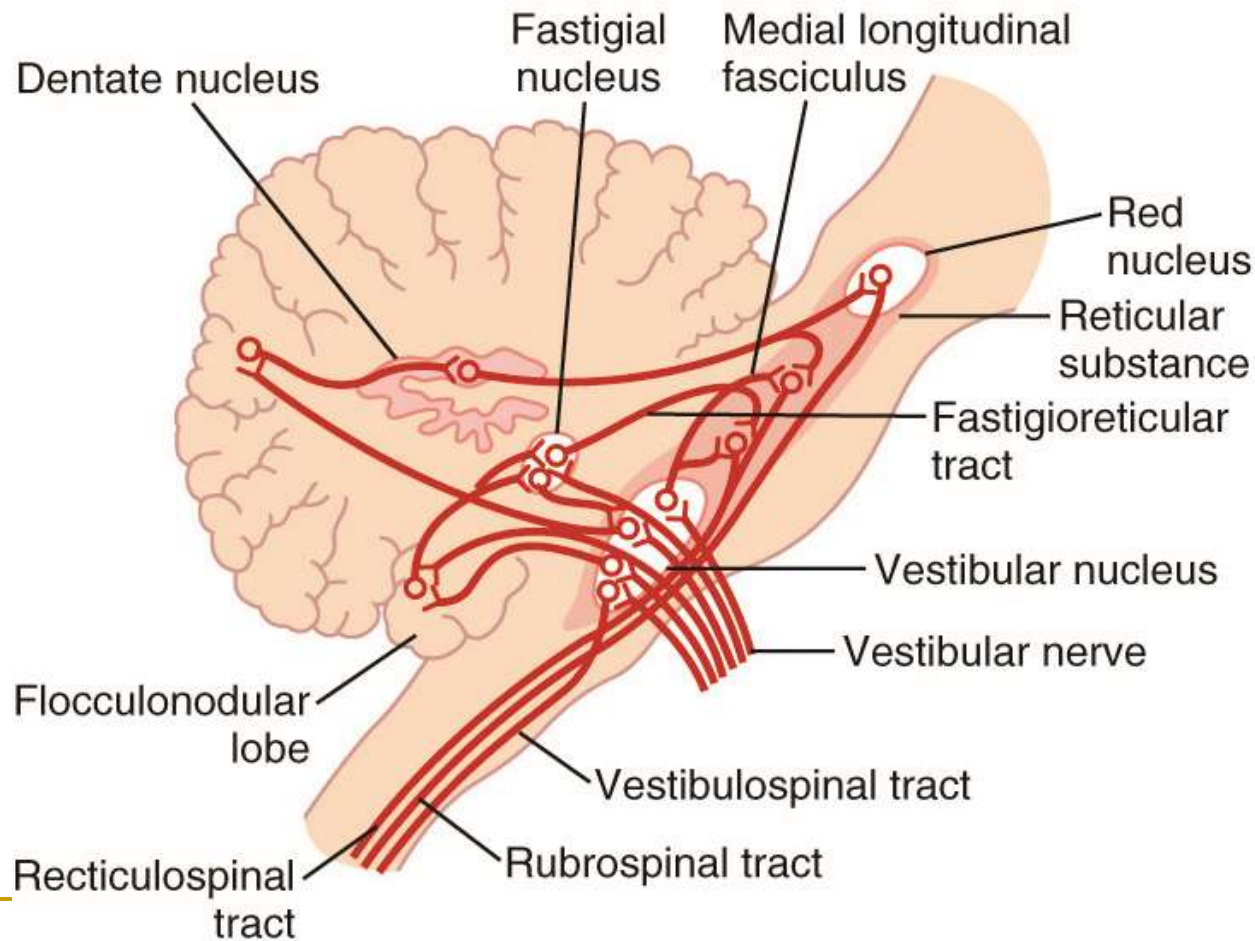

Vestibular Nuclear system

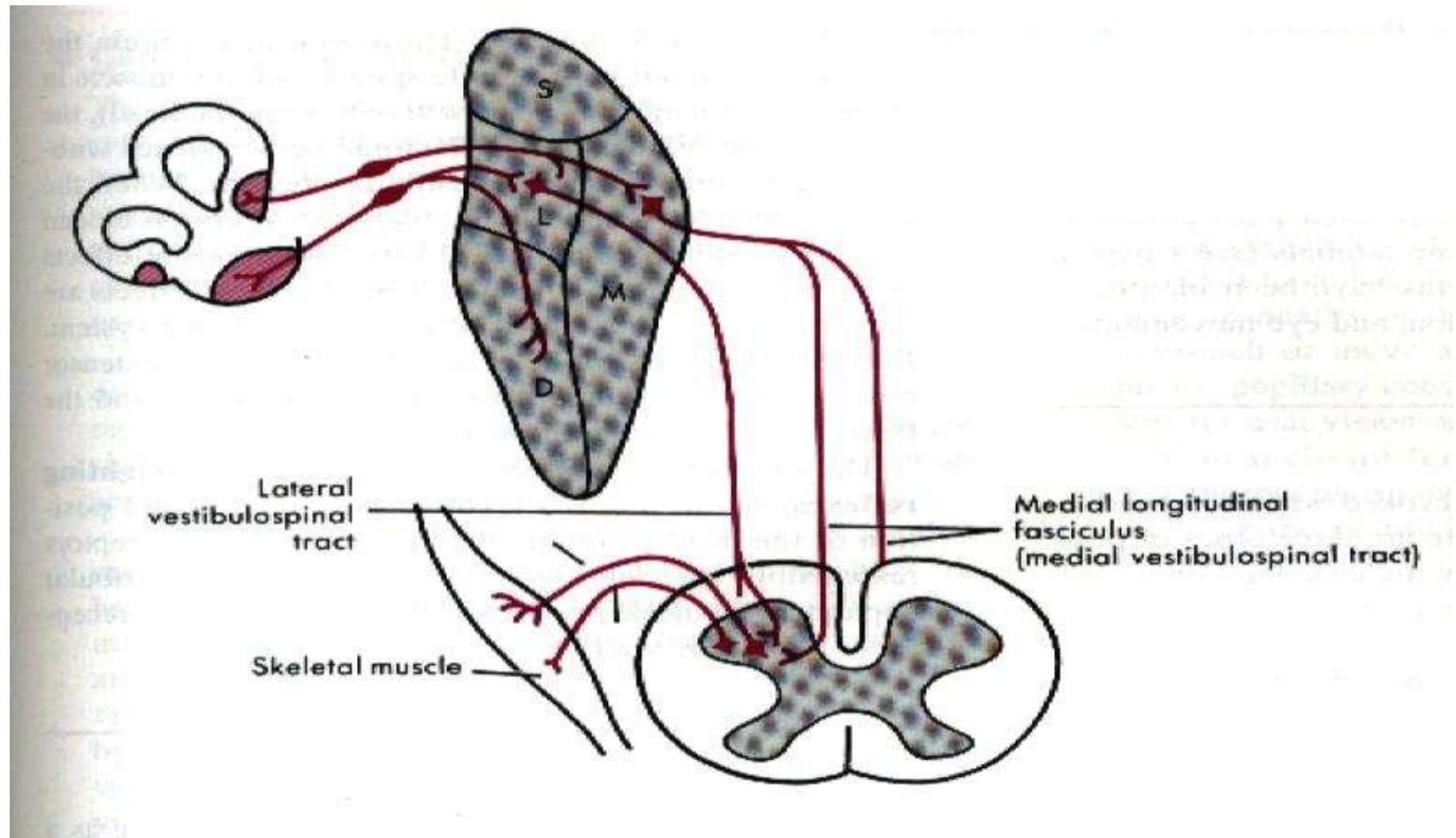

Vestibular Nuclei

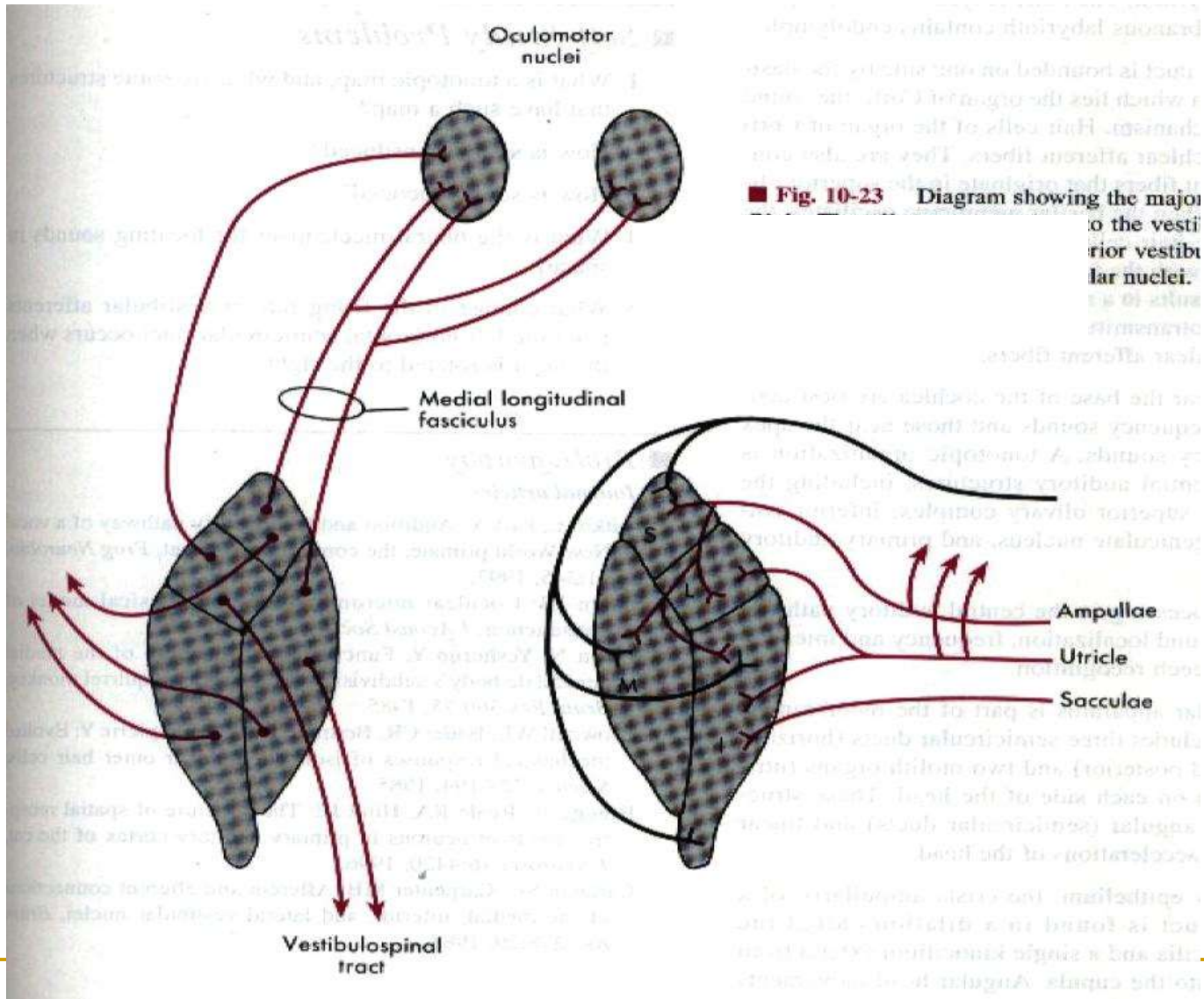

Red Nucleus and the Rubrospinal Tract

- Substantial input from primary motor cortex (Cortico rubral fibers)
- Primary motor cortex fibers synapse in the lower portion of the nucleus called the magnocellular portion which contains large neurons similar to Betz cells.
- Magnocellular portion gives rise to rubrospinal tract.
- Magnocellular portion has somatotopic organization similar to primary motor cortex.

Red Nucleus and the Rubrospinal Tract

- Stimulation of red nucleus causes relatively fine motor movement, but not as discrete as primary motor cortex. Control the movement of large flexors unlike corticospinal that controls the distal flexors concerned with fine precise movements.
- Accessory route for transmission of discrete signals from the motor cortex.

Red Nucleus and Rubrospinal Tract

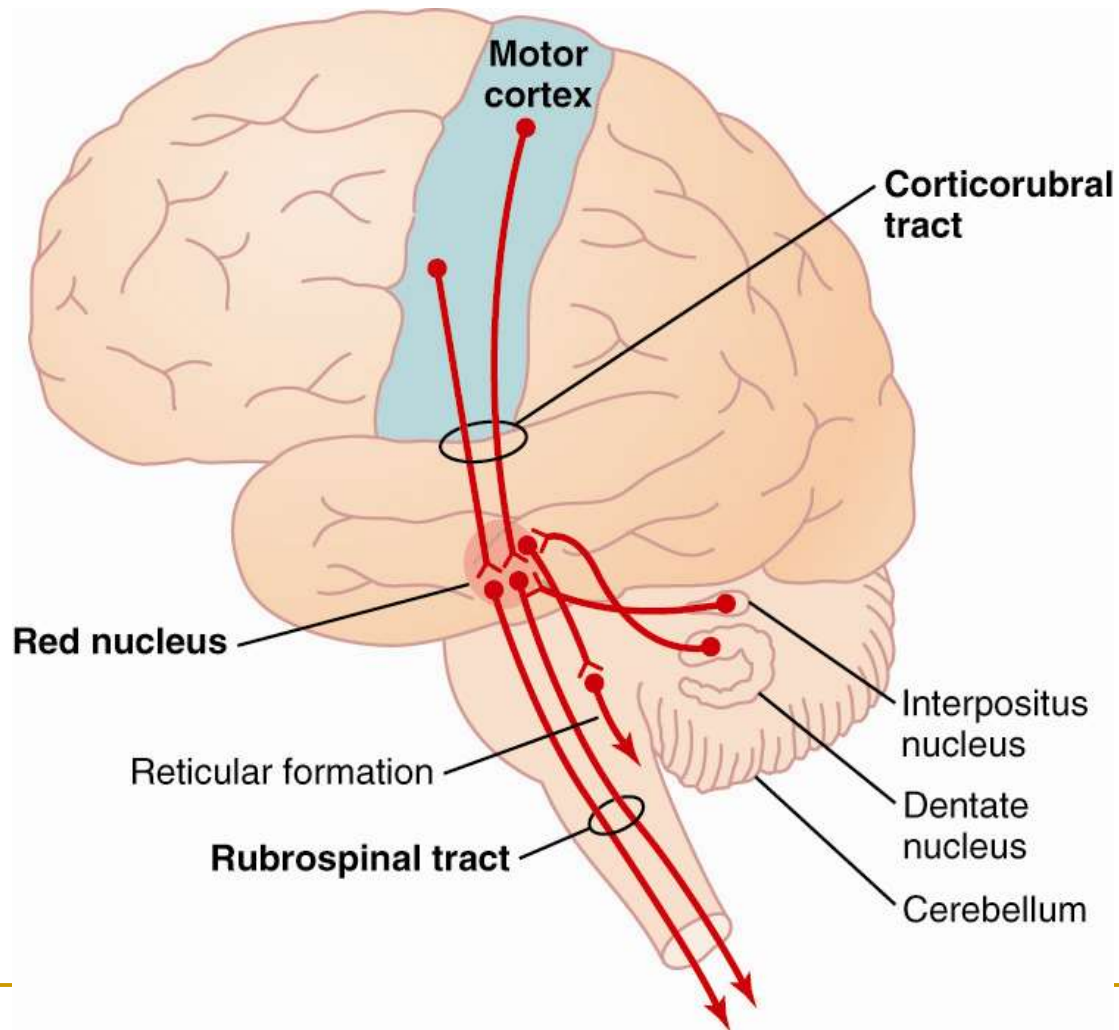

Thank You

