

Diuretics

Yacoub Irshaid MD, PhD, ABCP
Department of Pharmacology

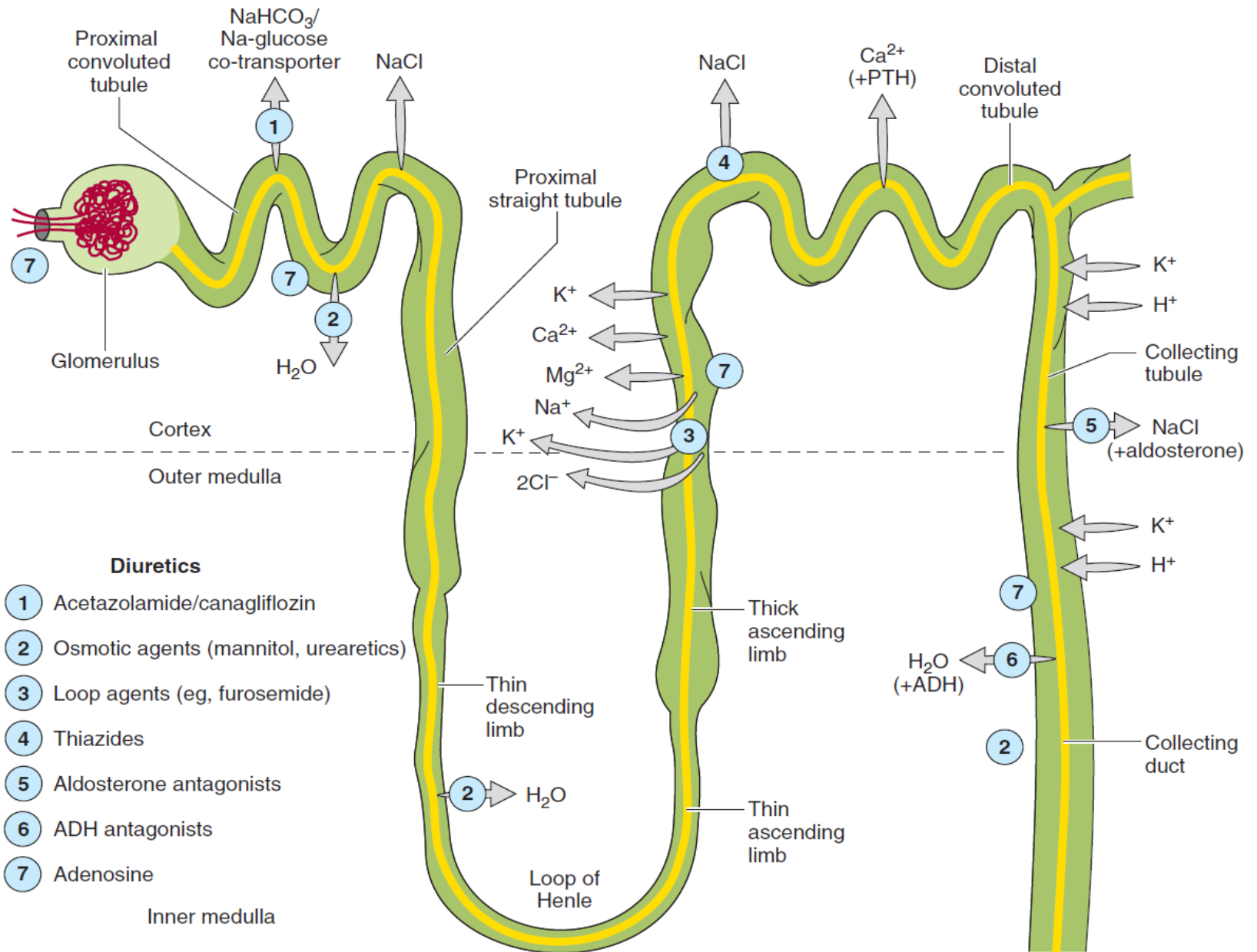

FIGURE 15-1 Tubule transport systems and sites of action of diuretics. ADH, antidiuretic hormone; PTH, parathyroid hormone.

Carbonic Anhydrase Inhibitors

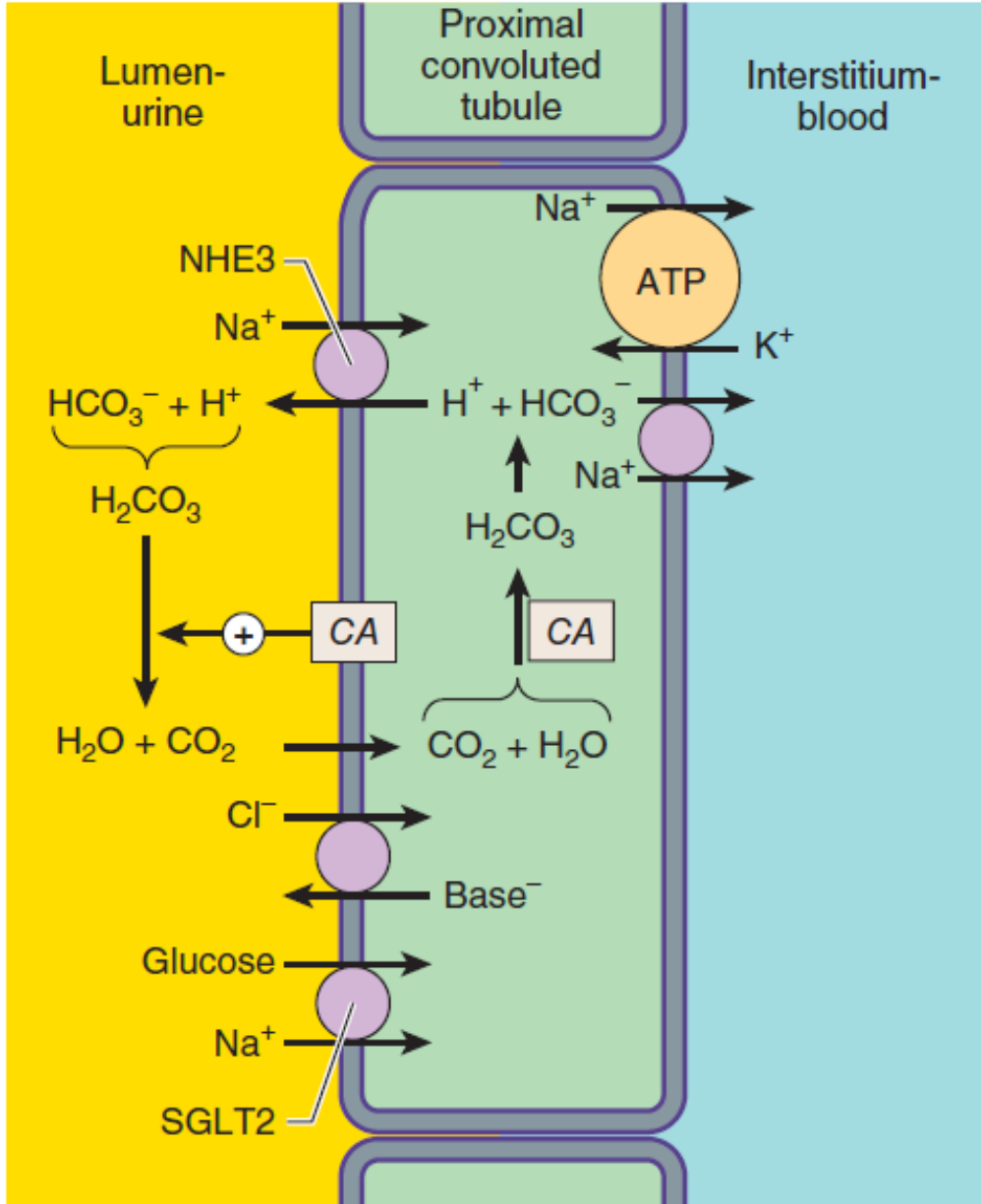

FIGURE 15–2:

- Apical membrane Na^+/H^+ exchange (via NHE3) and bicarbonate reabsorption in **the proximal convoluted tubule** cell.
- Na^+/K^+ -ATPase is present in the basolateral membrane to maintain intracellular sodium and potassium levels within the normal range.
- Because of rapid equilibration, concentrations of the solutes are approximately equal in the interstitial fluid and the blood.
- Carbonic anhydrase (CA) is found in other locations in addition to the brush border of the luminal membrane.
- SGLT2, $\text{Na}^+/\text{glucose}$ co-transporter.

Carbonic Anhydrase Inhibitors

Acetazolamide

Dichlorphenamide

Methazolamide

Pharmacological Actions:

1. Reduce sodium bicarbonate reabsorption in the proximal convoluted tubule. (85% of the HCO_3^- reabsorption capacity of PCT is inhibited).

Carbonic Anhydrase Inhibitors

- 2. Alkaline diuresis: HCO_3^- depletion \rightarrow enhanced NaCl reabsorption by the remainder of the nephron \rightarrow tolerance to their diuretic action (reduced efficacy) over several days.**
- 3. Reduce formation of aqueous humor by the ciliary body of the eye (HCO_3^- - dependent), and thus, intraocular pressure.**

Carbonic Anhydrase Inhibitors

- 4. Reduce formation of cerebrospinal fluid by the choroid plexus by a similar mechanism.**
- 5. Metabolic acidosis which increases the seizures threshold.**

Carbonic Anhydrase Inhibitors

Adverse Effects:

1. **Hyperchloremic metabolic acidosis due to reduction of body HCO_3^- stores.**
2. **Calcium phosphate renal stones.**
 - **Reduction of renal excretion of calcium solubilizing factors (citrate⁻) with chronic use.**
 - **Calcium phosphate is insoluble in alkaline urine.**

Carbonic Anhydrase Inhibitors

- 3. Renal potassium loss: Bicarbonate loss in urine increases negative charge in the collecting tubule which enhances potassium secretion.**
- 4. Hypersensitivity reactions (fever, rash, bone marrow suppression, interstitial nephritis).**

Carbonic Anhydrase Inhibitors

Contraindications:

- Alkalinization of the urine decreases urinary excretion of NH_4^+ (by converting it to rapidly reabsorbed NH_3) and may contribute to the development of hyperammonemia and hepatic encephalopathy in patients with liver cirrhosis.

Carbonic Anhydrase Inhibitors

Therapeutic Uses:

- 1. Rarely used as diuretics.**
- 2. Glaucoma, most common use, topical.**
- 3. Used for urinary alkalization to enhance elimination of acidic drugs and toxins**
- 4. Metabolic alkalosis**

Carbonic Anhydrase Inhibitors

- 5. Acute mountain sickness (high altitude 3000 m): By decreasing CSF formation and by decreasing the pH of the CSF and brain, they can improve ventilation and diminish symptoms of mountain sickness. This is also useful in the treatment of sleep apnea.**
- 6. Adjuncts in treatment of epilepsy.**

Thick ascending limb of loop of Henle

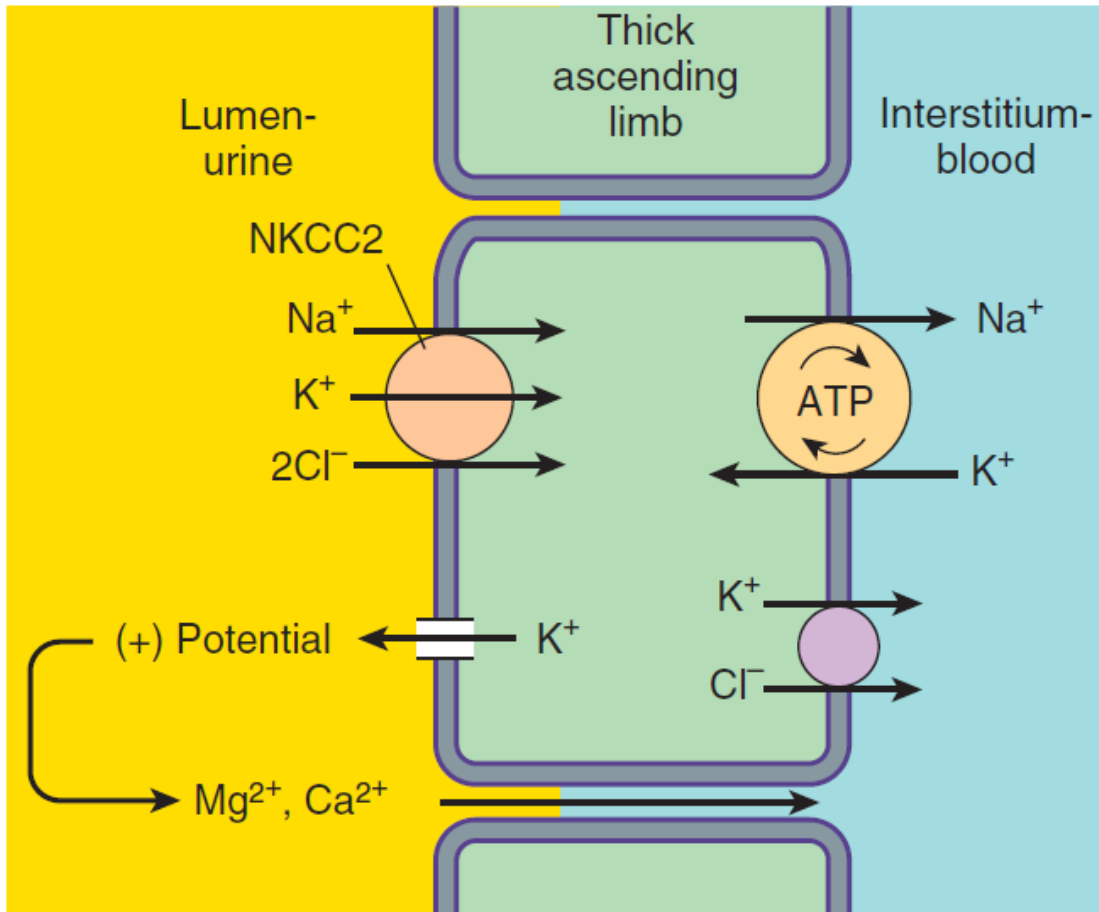

FIGURE 15–3:

- Ion transport pathways across the luminal and basolateral membranes of **the thick ascending limb** cell.
- Na^+ , K^+ , and 2Cl^- is the primary transporter in the luminal membrane.
- The lumen positive electrical potential created by K^+ back diffusion drives divalent (and monovalent) cation reabsorption via the paracellular pathway.

Loop Diuretics

- **Also called high ceiling diuretics.**
- **The most efficacious diuretic agents available.**
- **Tolerance does not develop to their diuretic action.**

Loop Diuretics

1. Sulfonamide derivatives:

- Furosemide, Bumetanide, Torsemide.

2. Phenoxyacetic acid derivatives:

- Ethacrynic acid.

Loop Diuretics

Pharmacological Actions:

- 1. Inhibit the luminal $\text{Na}^+/\text{K}^+/\text{2Cl}^-$ co-transporter in the thick ascending limb of Henle's loop.**
- 2. Diminish the lumen-positive potential that comes from K^+ recycling.**
- 3. Increase urinary loss of Na^+ , K^+ , Cl^- , Mg^{2+} and Ca^{2+} .**

Loop Diuretics

- 4. However, calcium is actively reabsorbed in the distal convoluted tubule and its intestinal absorption can be increased, thus, hypocalcemia is rare).**
- 5. Induce renal prostaglandin (PGE₂) synthesis (antagonized by NSAIDs) → increase renal blood flow, which contributes to the diuretic action.**

Loop Diuretics

- 6. Furosemide and ethacrynic acid reduce pulmonary congestion and reduce left ventricular filling pressure in heart failure before increasing urine output (this is also due to prostaglandins).**
- 7. Furosemide and bumetanide inhibit carbonic anhydrase also.**

Loop Diuretics

Pharmacokinetics:

- **Rapidly absorbed, and extensively bound to plasma proteins.**
- **Eliminated by tubular secretion as well as glomerular filtration.**
- **Furosemide and ethacrynic acid are partially metabolized.**
- **Torsemide has an active metabolite with a $t_{1/2}$ longer than that of parent compound.**

Loop Diuretics

Adverse Effects:

1. Hypokalemic metabolic alkalosis:

- By inhibiting salt reabsorption in the thick ascending limb, loop diuretics increase Na^+ delivery to the collecting duct. Increased Na^+ delivery leads to increased secretion of K^+ and H^+ by the duct, causing hypokalemic metabolic alkalosis.

Loop Diuretics

- 2. Ototoxicity & deafness – reversible, dose-related hearing loss.**
- 3. Hypomagnesemia: most often in patients with dietary magnesium deficiency**
- 4. Hyperuricemia: due to hypovolemia-associated enhancement of uric acid reabsorption in the proximal tubule, and competition for the organic acid transporter. May precipitate attacks of gout.**

Loop Diuretics

- 4. Allergic reactions (rash, eosinophilia & interstitial nephritis).**
- 6. Severe dehydration.**
- 7. Hyponatremia.**
- 8. Hypocalcemia (?)**
- 9. Hyperglycemia: due to hypokalemia-induced inhibition of insulin release.**

Loop Diuretics

Therapeutic Uses:

- 1. Acute pulmonary edema, Congestive heart failure – increase systemic venous capacitance.**
- 2. Acute hypercalcemia.**
- 3. Hyperkalemia: Effect is enhanced by simultaneous NaCl and water administration.**

Loop Diuretics

- 4. Acute renal failure: increase the rate of urine flow and enhance potassium excretion and ameliorate intratubular obstruction.**
- 5. Part of forced diuresis to enhance excretion of reabsorbable toxins and certain anions (Br^- , F^- , I^-). Saline solution must be administered to replace urinary losses of Na^+ and to provide Cl^- , so as to avoid extracellular volume depletion.**

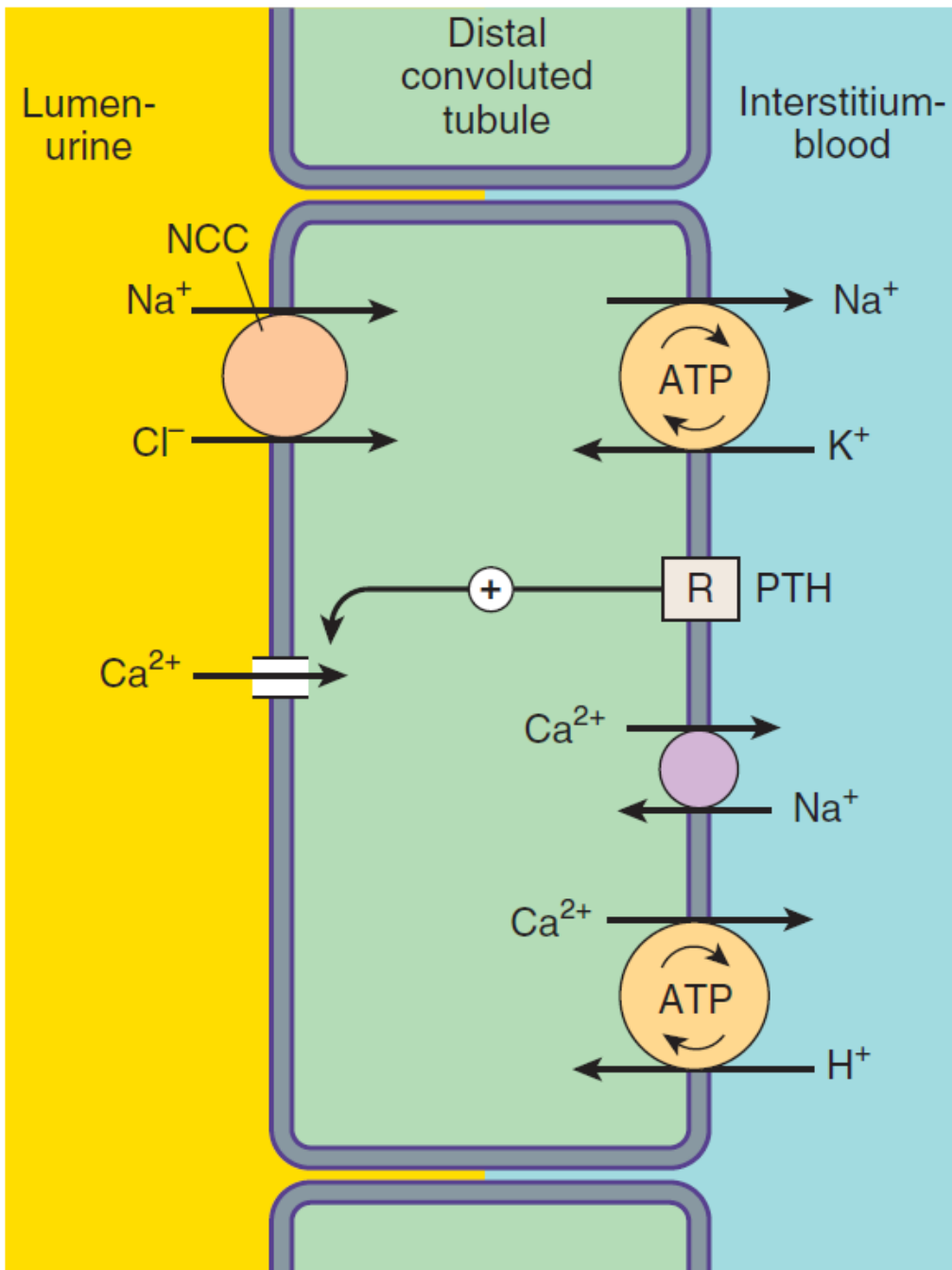

FIGURE 15-4

- Ion transport pathways across the luminal and basolateral membranes of the **distal convoluted tubule** cell.
- As in all tubular cells, Na⁺/K⁺-ATPase is present in the basolateral membrane.
- NCC is the primary sodium and chloride transporter in the luminal membrane.
- R, parathyroid hormone (PTH) receptor.

Thiazide Diuretics

**Hydrochlorothiazide, Chlorthiazide
Chlorthalidone.**

Indapamide, Metolazone.

- **All have unsubstituted sulfonamide group.**

Thiazide Diuretics

Pharmacological Actions:

- 1. Inhibit NaCl reabsorption from the distal convoluted tubule by blocking the electrically neutral, thiazide-sensitive Na^+/Cl^- co-transporter.**
- 2. Enhance Ca^{2+} reabsorption in the distal convoluted tubule. May be due to lowering of intracellular sodium which enhances $\text{Na}^+/\text{Ca}^{2+}$ exchange in the basolateral membrane.**

Thiazide Diuretics

- Thiazide-induced volume depletion leads to enhanced Na^+ and passive Ca^{2+} reabsorption in the proximal tubule.

3. Significant carbonic anhydrase inhibitory activity.

4. Actions depend, in part, on renal prostaglandin synthesis.

Thiazide Diuretics

Pharmacokinetics:

- **Can be used orally.**
- **Have differences in metabolism.**
- **Chlorthiazide is the only thiazide used parenterally. Not very lipid soluble.**
- **Chlorthalidone is slowly absorbed and has a long duration of action.**

Thiazide Diuretics

- **Indapamide is primarily excreted by the biliary system.**
- **All are actively secreted by the organic acid secretory system in the proximal tubule, and compete with uric acid for that system.**

Thiazide Diuretics

Adverse Effects:

1. **Hypokalemic metabolic alkalosis.**
 - **By inhibiting salt reabsorption in the distal convoluted tubules, thiazide diuretics increase Na^+ delivery to the collecting duct. Increased Na^+ delivery leads to increased secretion of K^+ and H^+ by the duct, causing hypokalemic metabolic alkalosis.**

Thiazide Diuretics

- 2. Hyperuricemia.**
- 3. Hyperglycemia – due to hypokalemia-induced inhibition of insulin release.**
- 4. Hyperlipidemia (increase cholesterol and LDL).**
- 5. Weakness, fatigue and parasthesia (CAI).**
- 6. Impotence (probably related to volume depletion)**

Thiazide Diuretics

- 7. Hyponatremia: is significant, due to:**
- **hypovolemia-induced elevation of ADH**
 - **reduction in the capacity of the kidney to produce dilute urine**
 - **increased thirst**
 - **extension of pharmacological action**

Thiazide Diuretics

- 8. Allergic reactions (hemolytic anemia, thrombocytopenia & acute necrotizing pancreatitis, necrotizing alveolitis, bone marrow suppression, dermatitis, cholestatic hepatitis).**
- 9. Photosensitivity.**

Thiazide Diuretics

Therapeutic Uses:

- 1. Hypertension**
- 2. Edema of:**
 - a. mild-moderate congestive heart failure**
 - b. hepatic and renal insufficiency**
- 3. Nephrolithiasis due to hypercalciuria**
Thiazides reduce urinary calcium

Thiazide Diuretics

4. Nephrogenic diabetes insipidus: NaCl & water loss in the distal nephron enhances NaCl & water absorption by the proximal nephron, and decreasing delivery of fluid to the diluting segment. Dietary sodium restriction can potentiate this effect.

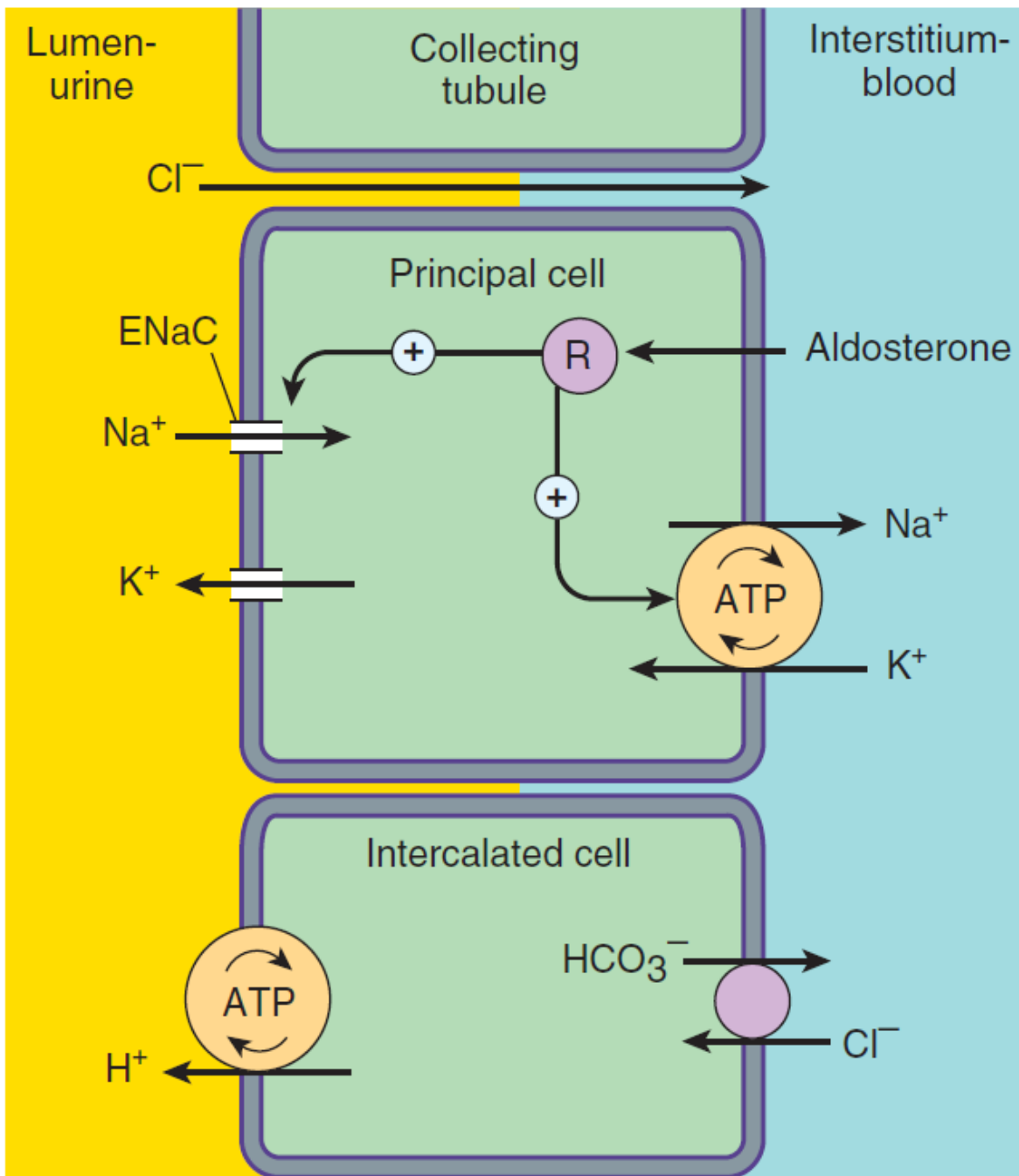

FIGURE 15–5

- Ion transport pathways across the luminal and basolateral membranes of **collecting tubule** and collecting duct cells.
- Inward diffusion of Na^+ via the **epithelial sodium channel** (ENaC) leaves a lumen-negative potential, which drives reabsorption of Cl^- and efflux of K^+ .
- R, aldosterone receptor.

Potassium Sparing Diuretics

A. Aldosterone Antagonists

Spironolactone , Eplerenone

Pharmacological Actions:

- **Block aldosterone receptors competitively and thus:**
 1. **Interfere with sodium & water reabsorption and potassium excretion in the collecting tubules.**

Potassium Sparing Diuretics

- 2. Also interfere with H⁺ handling in the intercalated cells.**

Such actions may depend on prostaglandin production.

Potassium Sparing Diuretics

Spironolactone:

Pharmacokinetics:

- Absorbed after oral administration.
- Extensive enterohepatic cycling.
- Extensive binding to plasma proteins.
- Canrenone is an active metabolite.

Potassium Sparing Diuretics

Adverse Effects:

- 1. Hyperkalemia: can be dangerous especially when combined with other drugs that increase potassium, such as, potassium supplements, NSAIDs, ACEIs, AT-blockers, β -blockers, etc.
OR in renal failure.**
- 2. Metabolic acidosis.**

Potassium Sparing Diuretics

3. Gynecomastia, Impotence and benign prostatic hyperplasia – not seen with eplerenone
4. GIT upset.

CAUTION:

1. Reduce dose in hepatic disease.
2. Ketoconazole and itraconazole can increase blood levels of eplerenone due to inhibition of CYP3A4.

Potassium Sparing Diuretics

B. **Amloride and Triamterene**

Pharmacological Action:

- 1. Do not block aldosterone receptors.**
- 2. Directly interfere with Na^+ entry through the selective ion channel in the collecting tubule.**
- 3. Since K^+ excretion is coupled with Na^+ entry, the effect is sparing of K^+ .**

Potassium Sparing Diuretics

- 4. The action may depend on renal prostaglandin production.**
- 5. Also inhibit H⁺ secretion in the distal nephron.**

Potassium Sparing Diuretics

Pharmacokinetics:

- **Amiloride is excreted unchanged in urine.**
- **Triamterene is metabolized in the liver, but renal excretion is a major route of elimination for the active form and metabolites.**
- **The metabolite has a shorter $t_{1/2}$ than amiloride.**

Potassium Sparing Diuretics

Adverse effects:

For both:

1. Hyperkalemia.
2. Nausea, vomiting, headache.
3. Metabolic acidosis.

For triamterene also:

1. Leg cramps, azotemia.
2. Interstitial nephritis.

Potassium Sparing Diuretics

3. **Nephrolithiasis (crystal formation).**
4. **Acute renal failure when given in combination with indomethacin, indomethacin inhibits renal prostaglandins while triamterene potentially causes tubulointerstitial damage or crystal formation.**
5. **Glucose intolerance.**
6. **Photosensitivity.**

Potassium Sparing Diuretics

Therapeutic Uses:

- 1. Mineralocorticoid Excess (1° , 2° or ectopic).**
- 2. In conjunction with other diuretics to reduce potassium loss.**
- 3. Hypokalemia (?)**

Osmotic Diuretics

Mannitol, Urea, Glycerin and Isosorbide.

- Agents that are filtered and NOT reabsorbed.
- Act within the proximal tubule and descending limb of Henle's loop – which are freely permeable to water.
- Also oppose ADH action in the collecting tubule.

Osmotic Diuretics

- They attract water from cells into the bloodstream (dilutional effect) → hyponatremia
- The nonreabsorbable solute prevents the normal absorption of water, thus reducing Na^+ as well as water reabsorption.
- The resulting natriuresis is of lesser magnitude than the water diuresis, leading eventually to excessive water loss and hypernatremia.

Osmotic Diuretics

Summary:

- Osmotic diuretics typically cause an initial, often temporary, decrease in serum sodium (hyponatremia) by pulling intracellular water into the extracellular space.
- However, as the drug induces significant water loss over sodium loss in urine, it can eventually lead to dehydration and hypernatremia.

Osmotic Diuretics

- **Attracting water in the lumen of renal tubules – increase urine volume and flow.**
- **Mannitol can increase renal blood flow through a prostaglandin- mediated mechanism, resulting in partial washout of normal medullary hypertonicity. It decreases net sodium reabsorption in Henle’s loop.**

Osmotic Diuretics

Mannitol

Pharmacokinetics:

- **Not absorbed orally, may cause osmotic diarrhea.**
- **Not metabolized.**
- **Excreted by glomerular filtration.**
- **No tubular secretion or reabsorption.**

Osmotic Diuretics

Therapeutic Uses:

- 1. To increase urine volume, to prevent acute renal failure from large pigment load to the kidney (from hemolysis and rhabdomyolysis). Some oliguric patients do not respond. (Why?)**
- 2. Reduction of intracranial pressure.**
- 3. Reduction of intraocular pressure in preparation for surgery.**

Osmotic Diuretics

- 4. To increase water excretion in preference to sodium excretion, when avid sodium retention limits the response to conventional diuretics.**

Osmotic Diuretics

Adverse Effects:

- 1. Extracellular volume expansion and hyponatremia (dilutional) prior to diuresis, pulmonary edema, congestive heart failure.**
- 2. Headache, nausea and vomiting.**
- 3. Dehydration and hypernatremia – free water loss. Excessive use without adequate water replacement.**

Osmotic Diuretics

4. **Hyperkalemia: due to intracellular dehydration → increase in intracellular K^+ concentration → leak of K^+ and hyperkalemia.**

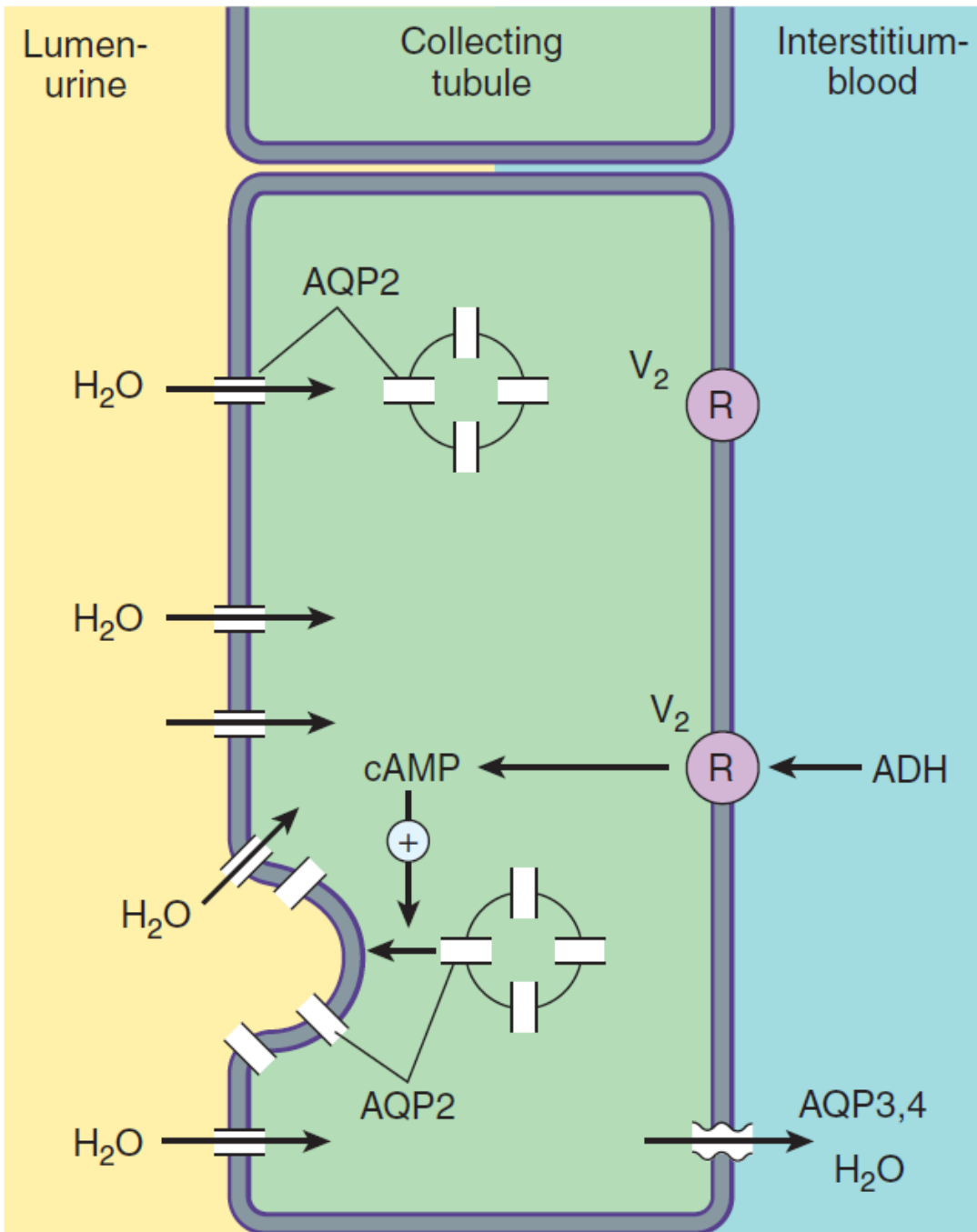

FIGURE 15–6:

- Water transport across the luminal and basolateral membranes of collecting duct cells.
- Above, low water permeability exists in the absence of antidiuretic hormone (ADH).
- Below, in the presence of ADH, aquaporins are inserted into the apical membrane, greatly increasing water permeability.
- AQP2, apical aquaporin water channels; AQP3,4, basolateral aquaporin water channels; V₂, vasopressin V₂ receptor.

Antidiuretic Hormone (ADH) Antagonists

- **Conivaptan** is a nonpeptide ADH receptor antagonist.
- **Nonselective agents: Lithium** (never used as ADHR antagonist) & **demeclocycline** (a tetracycline), is of limited use.
- They inhibit the effects of ADH in the collecting tubule by reducing the formation and action of cAMP.

Antidiuretic Hormone (ADH) Antagonists

- Used when ADH is elevated (SIADH & other causes).

Pharmacokinetics:

- Conivaptan can be orally absorbed, but it is used IV (not suitable for chronic use in outpatients).
- $t_{1/2} \sim 5-10$ hours.

Antidiuretic Hormone (ADH) Receptor Antagonists

Pharmacodynamics:

- **Inhibits ADH action in the collecting tubules by blocking vasopressin (ADH) receptors.**

Therapeutic uses:

- **Syndrome of Inappropriate ADH Secretion**

Antidiuretic Hormone (ADH) Receptor Antagonists

Adverse Effects:

1. Nephrogenic diabetes insipidus.
2. Severe hypernatremia.
3. Dry mouth and thirst
4. Hypotension